

KOMATSU

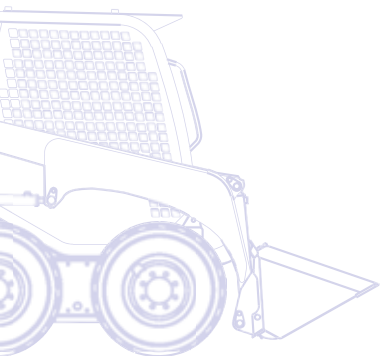

Skid Steer Loader

SK1020-5



ENGINE POWER
63,9 kW / 85,7 HP @ 2.500 rpm

OPERATING WEIGHT
3.420 kg

OPERATING CAPACITY
905 kg

Walk-Around

Highly versatile and compact, the SK1020-5 skid steer loader is the result of the competence and technology that Komatsu has acquired over the past 80 years. Developed with constant attention to the needs of customers from all around the world, the end product is a user-friendly skid steer loader with top-class performances.

Outstanding performances

- PPC hydraulic servo-controls
- Closed-centre Load Sensing System (CLSS)
- 2 speed transmission
- Bucket self-levelling
- Automatic Power Control device

Total versatility

- Compact dimensions
- Wide range of attachments
- Available in "Super Flow" version



SK1020-5

ENGINE POWER
63,9 kW / 85,7 HP @ 2.500 rpm

OPERATING WEIGHT
3.420 kg

OPERATING CAPACITY
905 kg

First-class operator comfort

- Spacious cab
- LCD panel
- Accelerator pedal



Highest safety standards

- ROPS-FOPS cab
- Safety sensors
- Excellent all around visibility
- Negative action brakes



Easy serviceability

- Easy access to all daily inspection points
- Tilting cab for full maintenance
- Extended 250-hour service interval

KOMTRAX

Komatsu Satellite
Monitoring System

Outstanding Performances

Highly efficient

A self-levelling bucket is one of the many standard features of this Komatsu skid steer loader that make it highly efficient in any application. The accelerator pedal and a 2 speed transmission further increase operator productivity.

PPC servo-controls

The PPC servo-controls make the SK1020-5 easy to use. Natural movements and maximum precision guarantee unique efficiency and greatly contribute to reduce operator fatigue. The right joystick controls the movements of the arm and of the bucket; the left one controls the translation.

Automatic Power Control device (APC)

Thanks to the APC device, the operator can always use the engine's full capacity, with no waste of power or overloads. It gives priority to the work equipment, makes the most of the residual power by sending it to the travelling motors, and prevents engine shutdown – even during the toughest operations.



First-Class Operator Comfort



Spacious cab

A spacious cab, with a wide entrance and comfortable seat, provides a level of comfort that is unmatched in this class of machines. Ergonomic controls and the excellent 360° visibility make the operator's work much easier and safer on any job site. On request, the SK1020-5 can be equipped with an exclusive front door that fits under the roof, and with side windows and heating or air conditioning for maximum comfort in all seasons.

LCD panel

The LCD panel on the safety bar allows to closely monitor all the machine's main functions: from fuel level to water temperature, air filter condition, engine oil pressure and more.

Accelerator pedal

For an optimised engine usage, lower fuel consumption and improved acoustic comfort the operator can also adjust engine rpm with the accelerator pedal without removing the hand from the joystick.

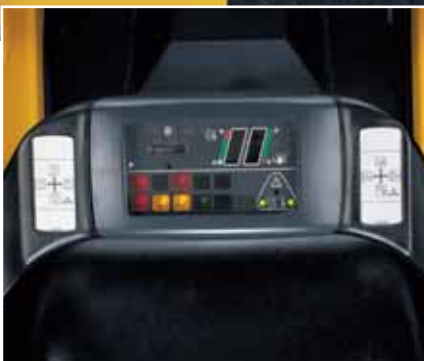

Highest Safety Standards



Safety sensors

In case of unauthorised manoeuvres, a sophisticated system of sensors located on the safety bars and on the seat prevents all machine movements by automatically braking on the transmission and inhibiting the PPC controls. The ROPS-FOPS cab, the excellent dynamic stability of the machine and a 360° visibility combine to give the operator complete confidence in any situation.



Brakes

The service and parking brakes are incorporated into the translation motors. They are hydraulic negative action brakes and can be set "on" or "off" with a button located on the board to the left of the operator. The brakes are always "on" when the engine is not running.



Multiple attachments

A wide range of attachments can be used with this machine, on many different job sites. Perfect for an everyday use on farms, building yards, industrial environments or harbours, the Komatsu skid steer loader stands in for manual labour with unparalleled versatility. The SK1020-5 is also available with an optional "Super Flow" hydraulic system, for using specialized attachments, and for extra power and flexibility.

Compact dimensions

Extremely compact, agile and fast, the SK1020-5 performs best in small places. Thanks to its short clearance circle and user friendly controls, steering operations are always possible in complete safety.



Easy Maintenance

Easy access to inspection points

Routine maintenance and check-ups can be performed by simply opening a rear bonnet that also allows the user to clean the inclinable radiators. For extra servicing, the tilting cab offers complete access to the transmission and to the main components of the hydraulic system. Special self-lubricating bushings increase the greasing intervals for all pins up to 250 hours.



The bonnet: quick engine check



The hatchback: simple inspection and cleaning of the radiators

Komatsu Satellite Monitoring System



KOMTRAX™ is a revolutionary machine tracking system designed to save you time and money. You can now monitor your equipment anytime and anywhere. Use valuable machine data received via the KOMTRAX™ web site to optimise your maintenance planning and machine performances.

With KOMTRAX™, you can:

- Check when & where your machines are at work
- Be informed of unauthorized machine use or movement
- Set and receive e-mail notification for security alarms

For further details on KOMTRAX™, please ask your Komatsu dealer for the latest KOMTRAX™ brochure.



Machine working time - With the "daily working record" chart, get precise engine running time data: when your machine was started and when it was shut down, as well as total engine running time.



Fleet location - The machine list instantly locates all your machines, even those in other countries.



Alarm notifications - You can receive notification of alarms both via the KOMTRAX™ website and by e-mail.



Added security - The "engine lock" feature allows to program when a machine's engine can be started. And with "geo-fence", KOMTRAX™ sends notification every time your machine moves in or out of a predetermined operating area.

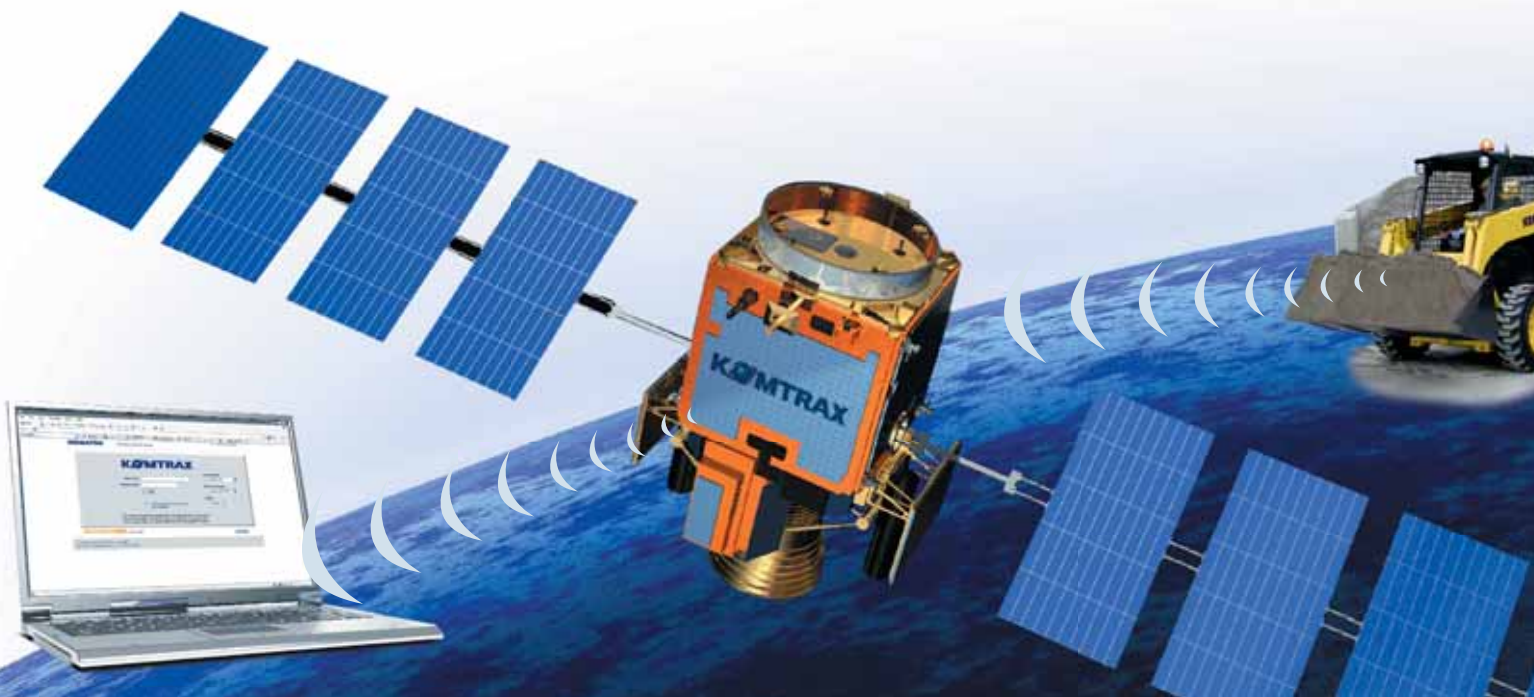

Specifications

ENGINE

The new generation engine has been developed to comply with the strictest emission controls.

Model	Komatsu SAD98E-2NFE
Type	4-cycle water-cooled diesel engine
Bore × stroke	98 × 100 mm
No. of cylinders	4
Engine power	
at rated engine speed	2.500 rpm
ISO 14396	63,9 kW / 85,7 HP
ISO 9249 (net engine power)	62,0 kW / 83,1 HP
Max. torque/engine speed	235 Nm / 1.600 rpm
Aspiration	turbo
Cooling system	water
Air filter type	dry with safety element
Starter motor	electric motor with pre-heating air system for cold climate

OPERATING WEIGHT

Operating weight with standard bucket, fully serviced, +75 kg operator (ISO 6016)	3.420 kg
---	----------

HYDRAULIC SYSTEM

Type	Komatsu CLSS
Hydraulic pump	gear pump
Max. pump flow	80 ltr/min
Max. operating pressure	210 bar
Control valve	3 elements fully servo-controlled SUPER FLOW hydraulic system (option):
Max. pump flow	130 ltr/min
Max. operating pressure	210 bar
Control valve	3 elements

TYRES

Standard	12-16.5 8PR
Option	12-16.5 8PR (narrow tread) 33 × 15.5-16.5 14PR (wide tyres)

CONTROLS

Proportional servo-controls (PPC). The left lever controls the machine movements, the right one controls the working equipment. The pedal controls the auxiliary circuit for attachments. A safety system neutralises all operations when the safety bars are risen or the operator is not seated.

TRANSMISSION

Type	hydrostatic
Pumps	2 × variable displacement with 2 stage
Hydraulic motors	2 × axial pistons
Constant mesh final transmission with “heavy duty” type roller chains, which are immersed in an oil bath.	
No. of travel speeds	2
Max. travel speed	16 km/h
Oil immersed discs for both parking and working breaks with negative action and automatic insertion.	

ELECTRIC SYSTEM

Voltage	12 V
Battery	100 Ah
Alternator	40 A

SERVICE CAPACITIES

Hydraulic system	50 ltr
Fuel tank	73 ltr
Hydraulic transmission (chains)	16 + 16 ltr
Engine oil	12,5 ltr

LOADER

Operating capacity (ISO 14397)	905 kg
Tipping load (ISO 14397)	1.810 kg
Standard bucket capacity (ISO 7546)	0,42 m ³
Bucket breakout force (ISO 14397)	2.242 daN (2.290 kg)
Max. loading height with forks	2.910 mm
Max. reach with forks	2.210 mm

ENVIRONMENT

Vibration levels (EN 12096:1997)*	
Hand/arm	≤ 2,5 m/s ² (uncertainty K = 1,2 m/s ²)
Body	≤ 0,5 m/s ² (uncertainty K = 0,2 m/s ²)
* for the purpose of risk assessment under directive 2002/44/EC, please refer to ISO/TR 25398:2006.	

Dimensions

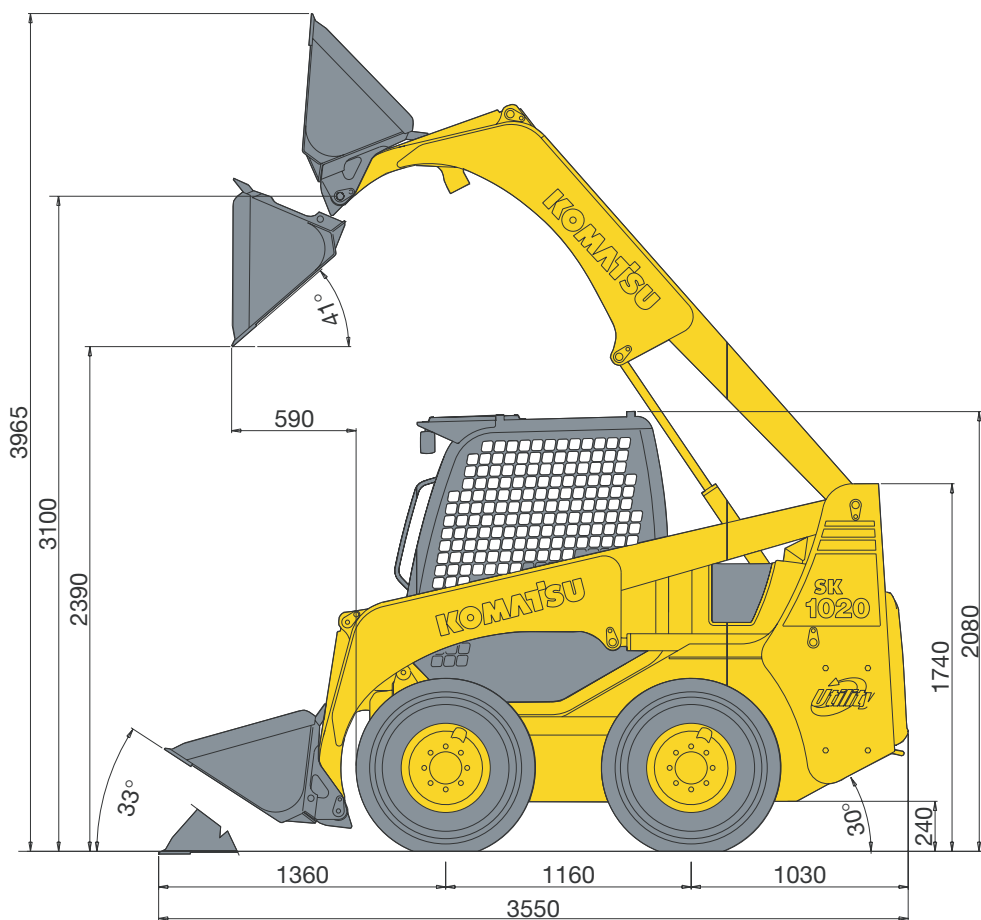
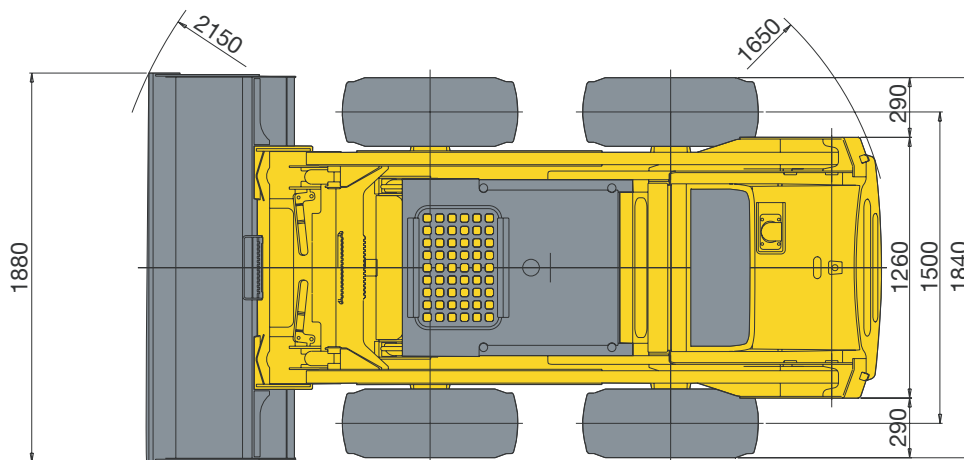

Skid Steer Loader

SK1020-5

Standard and Optional Equipment

ENGINE

Komatsu SAD98E-2NFE turbocharged, direct injection diesel engine	●
Alternator 40 A	●
Battery 100 Ah	●

TRANSMISSION

2 speed transmission	●
----------------------	---

HYDRAULIC SYSTEM

Auxiliary hydraulic circuit for attachments	●
Universal quick-coupler	●
Bucket floating function	●
SUPER FLOW version with 3 elements main valve (with drain line and electric connection)	○

TYRES AND BRAKES

Standard tyres 12-16.5 8PR	●
Automatic working and parking brakes	●
Narrow tread tyres 12-16.5 8PR	○
Wide tyres 33 × 15.5-16.5 14PR	○

SERVICE AND MAINTENANCE

KOMTRAX™ - Komatsu satellite monitoring system	●
Cyclone air pre-filter	○

CABIN

ROPS / FOPS (Class 1) tilting cab	●
Adjustable seat with safety belt	●
Safety bars with incorporated display	●
Instrument panel including:	
- hour meter	
- LCD fuel level indicator	
- LCD engine water temperature indicator	
- safety warning lights: operator onboard, safety bars lowered	●
- other pilot lights: air filter clogging, engine oil pressure, generator, hydraulic oil filter, engine pre-heating, parking brake, working lights, direction indicators, floating	
Accelerator pedal	●
12 V external power supply	●
Closed cab with side windows, door (with wiper) and heating or air conditioning	○
Deluxe suspension seat with safety belt	○
Fixed or sliding side windows	○
12 V internal power supply	○

SAFETY EQUIPMENT

Back-up alarm	●
Horn	●
Battery main switch	●
Rotating beacon	○
Accessories for road homologation	○
Rear view mirrors	○
FOPS Class 2 cab	○

LIGHTING SYSTEM

Two front working lights	●
2 rear working lights	○

OTHER EQUIPMENT

Bucket self leveling	●
Mudguards	○
Additional modular rear counterweight (6 pieces, total 126 kg)	○

ATTACHMENTS

1.880 mm bucket with or without teeth	●
1.730 mm bucket with or without teeth	○
2.030 mm bucket with or without teeth	○
Cutting edge on teeth	○
Bolt-on cutting edge	○
Pallet forks	○
Lifting hooks	○

A wide range of attachments is available. Please consult your distributor for details of the full range.

Other attachments on request

- standard equipment
- optional equipment

Your Komatsu partner:

KOMATSU

**Komatsu Europe
International NV**

Mechelsesteenweg 586
B-1800 VILVOORDE (BELGIUM)
Tel. +32-2-255 24 11
Fax +32-2-252 19 81
www.komatsu.eu

WESS006901 12/2010

Materials and specifications are subject to change without notice.
KOMATSU is a trademark of Komatsu Ltd. Japan.