

# KOMATSU®

## WA320-5

NET HORSEPOWER  
124 kW 166 HP @ 2.000 rpm

OPERATING WEIGHT  
14.475 kg

BUCKET CAPACITY  
2,7 - 4,5 m<sup>3</sup>

**WA**  
**320**

WHEEL LOADER



**WA320-5**

# WALK-AROUND

The new WA320-5 wheel loader: The perfect combination of performance, comfort and economy. Never-before experienced comfort in the SpaceCab cabin, enormous tractive force and lowest fuel consumption due to an innovative and efficient hydrostatic drive-line concept. Whisper-quiet in use, almost maintenance-free and incredibly productive. This is a wheel loader that has clearly earned its 5 stars!

## **Overwhelming Efficiency**

- High-torque low-emission engine with intercooler
- Extremely low fuel consumption
- Highest tractive effort
- Large breakout force
- Excellent stability
- Electronically controlled HST-drive (hydrostatic) with 2-motor system
- ECSS load stabiliser (option)
- Maximum dumping height and reach:  
Dumping height: 2.855 mm  
Dumping reach: 990 mm  
(with 2,7 m<sup>3</sup> universal bucket)

## **Diverse and Flexible**

- Comprehensive range of attachments for a wide variety of uses

## **Excellent Driving Convenience**

- SpaceCab™ cabin
- Optimum all-around view
- Interior sound level is only 73 dB(A)\*
- Series production electric controlled air conditioning as standard
- Electronically controlled HST with variable shift control system
- Traction Control System (TCS)
- Adjustable steering column
- Air-cushioned driver seat
- PPC short levers with F/R switch
- PPC-Multifunction lever with integrated F/R switch (option)



## **Ecological**

- Meets Step II emission regulations in Europe and USA
- Exterior sound level 105 dB(A)\*
- More than 95% of all materials can be recycled

**The 5 Star Loader**

\* ISO 6395 dynamic noise levels (2000/14/EC)

**NET HORSEPOWER**  
124 kW 166 HP

**OPERATING WEIGHT**  
14.475 kg

**BUCKET CAPACITY**  
2,7 - 4,5 m<sup>3</sup>

### **Long Service Life and Reliable**

- Reliable original Komatsu components
- Robust torsionally resistant frame
- Maintenance-free fully hydraulic, wet disc service and parking brakes
- Heavy-duty Torque Proportional Axles
- Sealed DT wiring harness connector
- Electronically controlled HST with overrun protection system



### **Easy Maintenance**

- EMMS monitoring system
- Swing-out fan drive
- Side-by-side type radiators for easy access and cleaning
- Gull-wing doors for easy ground level access
- Extended engine oil change interval
- Factory fitted automatic lubrication system

# HIGH PRODUCTIVITY

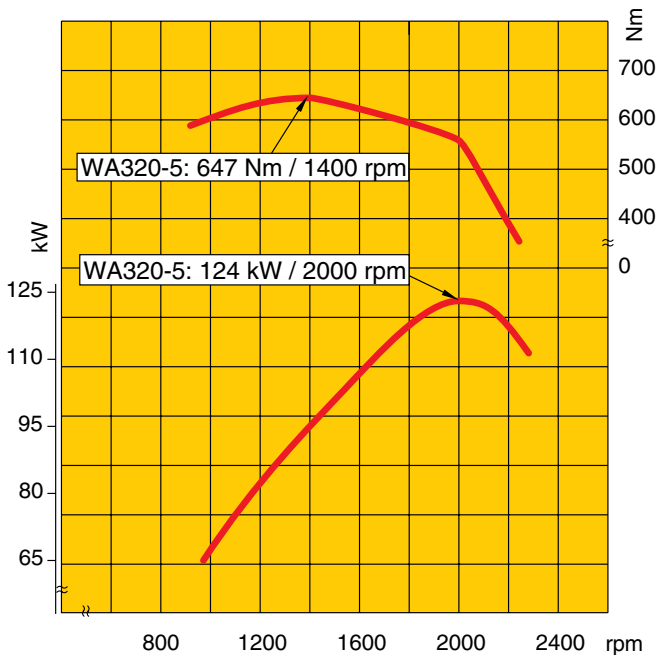

### High torque at low engine speeds

The net output of the Komatsu SAA6D102E low-emission engine is 124 kW (166 HP) at only 2.000 rpm. This means a constant, high power output with a 10% reduction in engine speed, compared with its predecessor. The high engine torque and the new hydrostatic drive line (HST) contribute to a substantial improvement in fuel consumption and climbing abilities. In load & carry as well as in loading operations, faster work cycles are achieved with simultaneous savings in fuel costs.

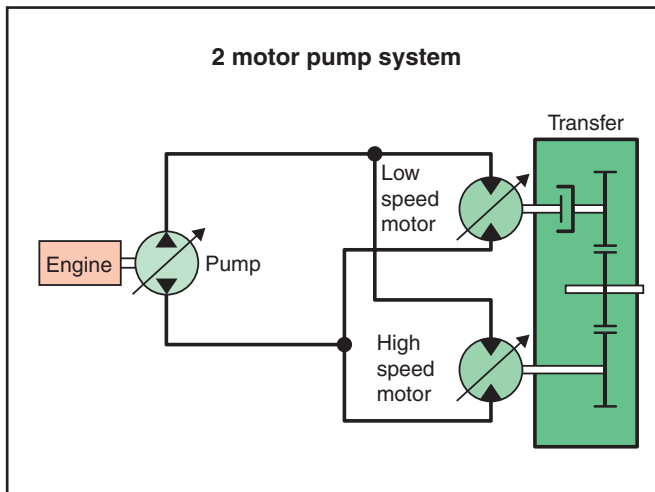

### Electronically controlled HST

The electronically controlled variable 2 pump motor system allows high-efficient and powerful operation. When the vehicle is travelling at high speed, the power transmitted between low-speed motor and axle is automatically cut off by the clutch for eliminating a drag-turning of the low-speed motor. Starting, gearshifting and piling-up on a slope is easy because there is no torque-off in the power train. Digging and scooping is easy as well, since maximum rimpull can be demonstrated even from zero travel speed.



### Traction Control System (TCS)

If the operator activates the traction control system, the maximum tractive effort is limited to 80%. This prevents tyre slip at light duty operations like stockpiling or on sandy ground and reduces tyre abrasion.

# BUCKETS AND ATTACHMENTS

The WA350-5 is outstanding due to its versatility. Whether used industrially in structural or civil engineering, earth-moving, road construction, agriculture, forestry or the timber industry, in landscaping companies and nurseries or in community services, the right solution is always available for your requirements.

The optional 4-point quick-coupler adds increased versatility to the machine and thus allows high-intensity operation.

Examples from the comprehensive range of original attachments are:



## Universal bucket

This type of bucket is impressive because of its excellent penetration and loosening properties and its good material holding properties. This universal bucket can be equipped with flush mount adapters and interchangeable teeth.



## Earthmoving bucket

The earthmoving bucket with a one-piece bucket bottom is suited both for earthworks and loading cohesive material. The slanted sides give powerful penetration. It is equipped either with flush mount adapters and interchangeable teeth or also with a rear removable edge.



## Stock pile bucket

The stock pile bucket is the right solution for handling loose and relatively light materials. The straight sidewalls ensure a high bucket capacity, the rear edge makes levelling and cleaning up jobsites easy. This stock pile bucket can be equipped with flush mount adapters and interchangeable teeth or a bolt-on cutting edge.



## Log grapple

Various versions available. With its sturdy structure and its great hydraulic power, the WA320 is also perfectly suited to work in the timber industry.



## Mulch grab bucket

Perfectly suited for picking up bulky and compressible materials like gardening or plastic waste, etc. Without the side plates, this bucket can be used also as a grapple.



## High dump bucket

For maximum dumping heights with light materials like coal or woodchips. The dump cylinders are located either inside or outside the bucket.

# THE SPACECAB



## **Perfect driving convenience and the best all-round visibility**

The cabin is one of the largest in its class and offers unparalleled driving convenience comparable to that of a passenger car. The large frameless windscreen ensures an optimum view of the bucket and tyres. The slanted rear end gives an excellent view towards the rear. The cabin is mounted on viscose shock absorbers guaranteeing a low interior sound level. That together with air conditioning as standard ensures the operator's well-being just as much as the air-cushioned multi-adjustable drivers seat with optional seat heater. The easy-to-work hydraulic operating controls (finger tip control levers or multifunction levers) allow to operate the wheel loader conveniently and ergonomically. The operator's well-being is ensured over long and productive hours.

# SIMPLE & CONVENIENT OPERATION

## Compact monitoring system

Arranged directly in front of the driver, an anti-dazzle, illuminated display makes it possible under all lighting conditions to read all instruments and information clearly. The driver's seat and steering column are infinitely-adjustable, allowing an ergonomic and comfortable seating position for any driver. All switches are logically arranged, and are outstanding on account of their functionality and ease of familiarisation.



## Easy and comfortable operation due to hydrostatic drive

The hydrostatic drive ensures maximum operating comfort. Speed and direction can be altered directly and without sudden jerks. The electronically controlled variable hydraulic motor enables full-auto shifting and eliminates gearshift and kick-down operations.



## Variable shift control

With the variable shift control, independent of the position of the accelerator pedal, and without loss of driving force, the travelling speed can be adjusted infinitely. This "creep function" has distinct advantages when working with attachments like a rotary cutter or a sweeper and provides improved operability at confined sites plus easier dozing operations.



## Smooth ergonomic hydraulic control

The new pilot control levers are designed as finger tip control levers for precise and fatigue-free control of the loading process. The position of the wristrest can be adjusted for all operators preferred height. A forward/reverse switch is located next to the levers so that the travel direction can be selected by touch.



## Multi-function lever (Option)

A multi-function lever with integrated forward/reverse switch is also available as optional equipment. The servo-assisted multi-function lever ensures the simplest and most comfortable operation of the equipment. Simultaneously, the driver can change between forward and reverse direction with the rocker switch. The multifunction lever is the right choice for earth moving jobs.



# SIMPLE AND FAST MAINTENANCE



## **Simple and convenient access to service**

The service doors are designed as gull-wing doors. They allow you convenient and safe access to the daily service points from the ground.



## **Easy maintenance due to swing-out fan**

The swing-out cooling fan allows quick and easy cleaning of the radiator. The fan is hydraulically driven and separated from the engine compartment.

This innovative system features:

- Swing-out cooling fan for excellent access
- High-efficiency fan and shroud
- Very low-noise operation

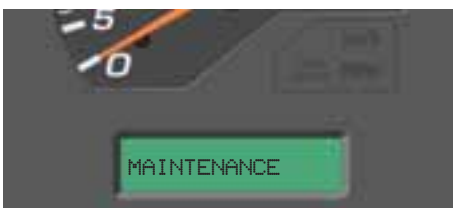

## **EMMS (Equipment Management Monitoring System)**

This completely new type of monitoring system is clearly structured and easy to read because it is directly in the operators field of view. If there is a malfunction, it immediately displays the details in the chosen national language and in plain text in the display field. This system not only has an error memory and a self-diagnosis function, but also a service interval display. This significantly simplifies service work and the operator is notified on time of the regular oil and filter changes. The operator and customer-service engineer are constantly informed about the optimum machine state so that problems don't even occur in the first place.



# LONGEVITY AND RELIABILITY

## Quality you can rely on!

The engine, hydraulics, power train, front and rear axles are original Komatsu components. All of these component parts are subject to the highest quality requirements and strict quality assurance right down to the smallest screw. They are fully co-ordinated with one another, thus offering maximum efficiency and reliability.

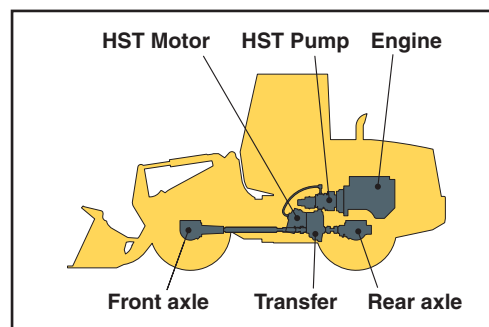

## Torsionally resistant frame

The frame design with hinge points far apart guarantees the high stability for the overall construction and reduces bearing stress in the torsional ranges. Steering angles of 40° give the WA320-5 a high degree of manoeuvrability.



## Robust HD-axes with TPD or LSD differential

The heavy-duty axles allow above-average service life even under the hardest working conditions. The WA320-5 can be equipped with torque proportional or multiple-disc limited slip differentials to further increase tractive force.



## Reliable construction equipment engines

Komatsu's reliable engine, with thick walled crank case, was developed with low noise and robustness in mind. The integrated overrun protection system restricts the top speed when driving downhill, thus protecting the power train and drive system.



## Reliability right down to the details

All of the hydraulic connections are reliably protected against oil loss by Komatsu's O-ring seals. The electrical system is also designed for long-lasting operation (without breakdowns) with its dust- and water-proof DT plug-and-socket connections in the wiring harnesses.

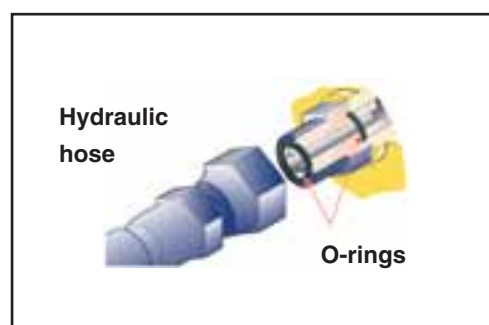

# DIMENSIONS AND PERFORMANCE FIGURES

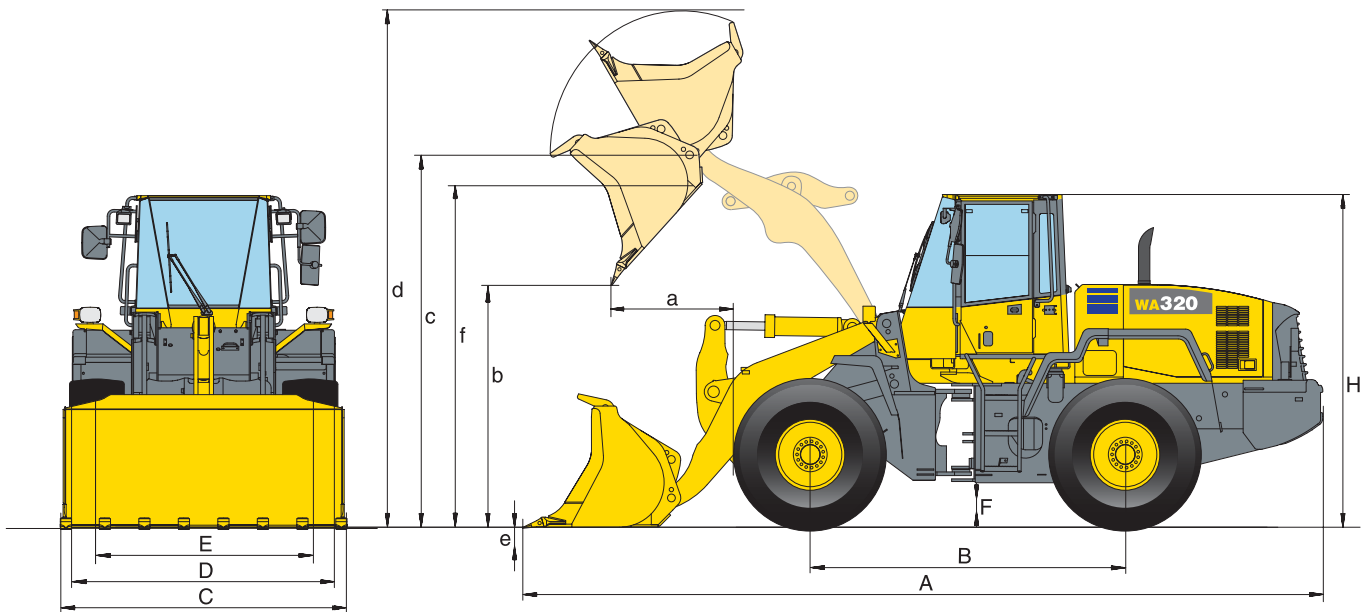

**Measurements and working specifications**

| Bucket type                               |                      | Universal  |            | Earthmoving |            | Stockpile  |            |
|---|----------------------|------------|------------|-------------|------------|------------|------------|
|   |                      | w/o teeth  | with BOC   | w/o teeth   | with BOC   | w/o teeth  | with BOC   |
| <b>Bucket capacity (heaped, ISO 7546)</b> | <b>m<sup>3</sup></b> | <b>2,7</b> | <b>2,9</b> | <b>2,7</b>  | <b>2,9</b> | <b>3,0</b> | <b>3,1</b> |
| Sales Code                                | 3924-                | C01        | C03        | C41         | C43        | C31        | C33        |
| Material density                          | t/m <sup>3</sup>     | 1,8        | 1,65       | 1,8         | 1,65       | 1,6        | 1,5        |
| Bucket weight without teeth               | kg                   | 1.040      | 1.255      | 1.120       | 1.325      | 1.265      | 1.475      |
| Static tipping load, straight             | kg                   | 12.000     | 11.785     | 11.920      | 11.715     | 11.775     | 11.565     |
| Static tipping load, 40° articulated      | kg                   | 10.355     | 10.140     | 10.275      | 10.070     | 10.130     | 9.920      |
| Break-out force hydraulic                 | kN                   | 134        | 125        | 134         | 125        | 130        | 120        |
| Lifting capability hydr. at ground level  | kN                   | 155        | 153        | 155         | 153        | 154        | 152        |
| Operating weight (without add. counterw.) | kg                   | 14.040     | 14.255     | 14.120      | 14.325     | 14.265     | 14.475     |
| Turning radius at corner of tyres         | mm                   | 5.475      | 5.475      | 5.475       | 5.475      | 5.475      | 5.475      |
| Turning radius at bucket edge             | mm                   | 6.085      | 6.125      | 6.085       | 6.125      | 6.085      | 6.125      |
| a Reach at 45°                            | mm                   | 990        | 1.030      | 990         | 1.030      | 1.040      | 1.090      |
| b Dump height at 45°                      | mm                   | 2.855      | 2.805      | 2.855       | 2.805      | 2.830      | 2.780      |
| c Hinge pin height                        | mm                   | 3.910      | 3.910      | 3.910       | 3.910      | 3.910      | 3.910      |
| d Height top edge of bucket               | mm                   | 5.260      | 5.260      | 5.260       | 5.260      | 5.380      | 5.380      |
| e Digging depth                           | mm                   | 105        | 105        | 105         | 105        | 105        | 105        |
| f Max. loading height at 45°              | mm                   | 3.610      | 3.610      | 3.610       | 3.610      | 3.610      | 3.610      |
| A Overall length, bucket grounded         | mm                   | 7.475      | 7.540      | 7.475       | 7.540      | 7.515      | 7.625      |
| B Wheelbase                               | mm                   | 3.030      | 3.030      | 3.030       | 3.030      | 3.030      | 3.030      |
| C Bucket width                            | mm                   | 2.740      | 2.750      | 2.740       | 2.750      | 2.740      | 2.750      |
| D Width over tyres                        | mm                   | 2.525      | 2.525      | 2.525       | 2.525      | 2.525      | 2.525      |
| E Track width                             | mm                   | 2.050      | 2.050      | 2.050       | 2.050      | 2.050      | 2.050      |
| F Ground clearance                        | mm                   | 440        | 440        | 440         | 440        | 440        | 440        |
| H Overall height                          | mm                   | 3.200      | 3.200      | 3.200       | 3.200      | 3.200      | 3.200      |

All measurements with tyres 20.5 R25 L3. Details of dumping heights and reach to cutting edge or bolt-on cutting edge.  
 Details given are for buckets without teeth; if equipped with teeth: dump height -165 mm, dump reach +165 mm, overall length +255 mm.  
 Change in data caused by add. counterweight: weight +520 kg, stat. tipping load straight +920 kg, stat. tipping load 40° angle +660 kg  
 Change in data caused by equipment with teeth: weight +100 kg, stat. tipping load straight -65 kg, stat. tipping load 40° angle -125 kg, length +65 mm

# SPECIFICATIONS



## ENGINE

|                           |  |
|---------------------------|--|
| Type .....                | Komatsu SAA6D102E<br>water-cooled, 4-stroke, turbocharged,<br>with air-to-air intercooler            |
| Rated power .....         | 124 kW/166 HP (SAE J1349)<br>at engine speed .....2.000 rpm  |
| Torque/engine speed ..... | max. 647 Nm/1.400 rpm  |
| No. of cylinders .....    | 6  |
| Bore/stroke .....         | 102/120 mm   |
| Displacement .....        | 5,9 l  |
| Injection system .....    | Direct injection   |
| Lubricating system .....  | Gear pump, pressure feed lubrication filter  |
| Filter .....              | Main-flow filter   |
| Electrical system .....   | 24 V   |
| Battery .....             | 110 Ah   |
| Alternator .....          | 60 A   |
| Air-filter type .....     | Dry-air filter with automatic<br>dust emission and preliminary purification including a dust display |



## TRANSMISSION

|   |   |
|---|---|
| Drive system .....                      | Electronically controlled hydrostatic transmission,<br>switchable in all directions under full power<br>Fixed ratio gearbox. Variable speed limiter |
| Hydrostatic pump .....                  | 1 variable piston pump  |
| Hydrostatic motor .....                 | 2 variable piston motors  |
| Speed ranges (forwards/backwards) ..... | 4/4   |
| Max. travel speeds (forwards/backwards) |   |
| 1./2. speed range .....                 | 13 km/h   |
| 3. speed range .....                    | 18 km/h   |
| 4. speed range .....                    | 38 km/h   |



## CHASSIS AND TYRES

|                      |   |
|----------------------|---|
| System .....         | 4-wheel drive   |
| Front axle .....     | HD axle, semi-floating, fixed type<br>LSD/TPD-differential                          |
| Rear axle .....      | HD axle, semi-floating, center-pin support<br>LSD/TPD-differential, 30° swing angle |
| Reduction gear ..... | Spiral bevel gear   |
| Differential .....   | Straight bevel gear pair  |
| Final drive .....    | Planetary gear in an oil bath   |
| Tyres .....          | 20.5 R25 (standard)   |



## SERVICE REFILL CAPACITIES

|                                       |        |
|---------------------------------------|--------|
| Cooling system .....                  | 20 l   |
| Fuel tank .....                       | 228 l  |
| Motor oil .....                       | 19,5 l |
| Hydraulic system .....                | 89 l   |
| Axle (both front and rear axle) ..... | 24 l   |
| Transfer .....                        | 6,5 l  |



## BRAKES

|                        |   |
|------------------------|---|
| Operating brakes ..... | Completely hydraulic dual-circuit system,<br>running in oil bath<br>multi-disc brakes<br>on all wheels,<br>service-free |
| Parking brake .....    | Operated mechanically,<br>running in oil bath<br>multi-disc brake,<br>service-free                                      |
| Emergency brake .....  | Independent service brake system  |



## HYDRAULIC SYSTEM

|  |                            |
|--|----------------------------|
| Hydraulic pump .....                             | Gear pump                  |
| Working pressure .....                           | 210 bar                    |
| Circulating capacity of the hydraulic pump ..... | 167 + 58 l/min             |
| No. of boom/bucket cylinders .....               | 2/1                        |
| Type .....                                       | Double-action              |
| Bore diameter × stroke                           |                            |
| Boom cylinder .....                              | 140 × 740 mm               |
| Bucket cylinder .....                            | 160 × 532 mm               |
| Hydraulic control lever .....                    | Servo-controlled, 2-levers |
| Hydraulic cycle with rated load bucket filling   |                            |
| Raise time .....                                 | 6,1 s                      |
| Lowering time (empty) .....                      | 3,3 s                      |
| Dumping time .....                               | 1,2 s                      |



## STEERING SYSTEM

|   |                                     |
|---|-------------------------------------|
| System .....  | Articulated frame steering          |
| Type .....  | Completely hydraulic power steering |
| Steering angle to either side .....                   | 40°                                 |
| Steering pump .....                                   | Gear pump                           |
| Working pressure .....                                | 210 bar                             |
| Pumping capacity .....                                | 167 l/min                           |
| No. of steering cylinders .....                       | 2                                   |
| Type .....  | Double-action                       |
| Bore diameter × stroke .....                          | 70 × 453 mm                         |
| Smallest turn (outer edge of the tyre 20.5 R25) ..... | 5.475 mm                            |



## CABIN

Two-door cabin in conformity with ISO 3471 with ROPS (roll over protective structure) in conformity with SAE J1040c and FOPS (falling object protective structure) in conformity with ISO 3449. The air-conditioned pressurised cabin is mounted upon hydrobearings and is noise dampened. Noise level inside cabin: 73 dB(A)

# WHEEL LOADER

## STANDARD EQUIPMENT

- Universal bucket 2,7 m<sup>3</sup> (SAE, heaped)
- Z-bar boom
- PPC fingertip control, 2-levers
- 2-spool main control valve
- Automatic central lubrication
- Counterweight
- Automatic return-to-dig
- Automatic boom kick-out
- Swing-out radiator fan drive
- Power train guard
- Tyres 20.5 R25 L-2
- Heavy-duty axles
- TPD-differential front and rear
- Electronically controlled HST with 2-motor system
- Constant speed control in 1st speed range

- Alternator 60 A
- Starter motor 4,5 kW/24 V
- Batteries 110 Ah/2 × 12 V
- Spacious double door driver's cab to DIN/ISO
- ROPS/FOPS frame to SAE
- All-round tinted glazing
- Front laminated glass
- Electr. controlled air conditioning
- Heated rear window
- Rear window wiper
- Air-suspended seat
- Sun visor
- EMMS (Equipment Management Monitoring System) with self-diagnostic function and maintenance display

- Seat belt (EU standard)
- Traction control system (TCS)
- Adjustable steering column
- Stereo-cassette radio
- 2 halogen main headlights
- 2 spotlights at front and rear
- Reversing light
- Horn
- Emergency steering system
- Vandalism protection
- Tool-set

The WA320-5 is equipped in accordance with the safety regulations of the machinery guidelines 89/392 EWG ff and EN474, and corresponds in its exhaust gas emission values with the regulations of the EC 2000/14, VIII and EC 97/68 Stage II regulations.

## OPTIONAL EQUIPMENT

- 3-spool main control valve
- Quick-coupler
- Add. counterweight 520 kg
- Electronically controlled load stabilizer (ECSS)
- Limited-slip differential (LSD) front and rear
- Tyres 650/65 R25
- Tyres 20.5 R25 L3, L4, L5
- Universal bucket 2,9 m<sup>3</sup>
- Earthmoving bucket 2,7 m<sup>3</sup>
- Earthmoving bucket 2,9 m<sup>3</sup>
- Stock pile bucket 3,0 m<sup>3</sup>
- Stock pile bucket 3,1 m
- Light materials bucket 4,5 m<sup>3</sup>
- High-Dump bucket 3,0 m<sup>3</sup>
- High-Dump bucket 4,5 m<sup>3</sup>
- High-Dump bucket 7,0 m<sup>3</sup>

- All buckets direct or quick-coupler mount
- Various tooth systems, BOC, segments, (Komatsu/KVX™) and other optional bucket accessories are available on request
- Log grapples
  - Special buckets
  - PPC control, 1-lever (Multi-function lever)
  - Back-up alarm
  - Beacon light
  - Additional lights front and rear
  - Front screen protective grid
  - Turbo II pre-filter
  - Electronic anti-theft lock
  - Battery main switch

- Fire extinguisher
- Biodegradable oil for hydraulic system
- Special custom colour
- Wastehandler specification
- Anti-Corrosion specification

Further equipment on request



**Komatsu Europe International NV**  
 Mechelsesteenweg 586  
 B-1800 VILVOORDE (BELGIUM)  
 Tel. +32-2-255 24 11  
 Fax +32-2-252 19 81  
 www.komatsueurope.com