

KOMATSU®

PC240LC-7 PC240NLC-7

NET HORSEPOWER
125 kW 168 HP @ 2.000 rpm

OPERATING WEIGHT
PC240LC-7: 24.200 - 26.400 kg
PC240NLC-7: 23.500 - 25.650 kg

BUCKET CAPACITY
0,48 - 1,89 m³

PC
240

HYDRAULIC EXCAVATOR



PC240LC/NLC-7

WALK-AROUND

The PC240-7 is a rugged, productive, all-European machine. Designed and expressly built for European markets, it delivers productivity, reliability and operator comforts in a robust, environmentally-friendly package. Komatsu's exclusive, on-board, HydraMind system assists in all operations, providing enhanced machine performance that's always perfectly matched to the task.

What's new on Dash 7:

- Higher production
- Low fuel consumption
- Easier maintenance and serviceability
- Improved operator comfort
- Lower noise
- Meets EC Stage II emission regulations
- Advanced Attachment Control
- Multi-function colour monitor

Advanced Attachment Control

The PC240-7 can be optionally equipped to handle a wide variety of attachments. The advanced attachment control system features:

- Operator selectable hydraulic flow control
- Adjustable presets for rapid attachment changeover
- Additional filters and accumulators for attachment and machine protection
- Hydraulic relief pressure control
- Automatic changeover valves
- Attachment piping options

Heavy-duty digging performance

Large bore cylinders have been installed to the super short and short arms to greatly increase digging force and productivity in tough conditions. The boom and arms have larger cross sections to provide superb durability.

High productivity and low fuel consumption

The powerful turbocharged and air-to-air aftercooled Komatsu SAA6D102E-2 provides 125 kW/168 HP. Productivity has increased with greater output in the 'Active' mode, while fuel efficiency has been further improved.



Maximum digging height: 10 m

An advantage for jobs that require a longer reach.

Excellent reliability and durability

- Heavy-duty work equipment
- Reliable major components designed and built by Komatsu
- Exceptionally-reliable electronic devices

Greater lifting capacity

Lateral stability has been improved and the lifting capacity has increased.

NET HORSEPOWER
125 kW 168 HP

OPERATING WEIGHT
PC240LC-7: 24.200 - 26.400 kg
PC240NLC-7: 23.500 - 25.650 kg

BUCKET CAPACITY
0,48 - 1,89 m³

Easy maintenance

- Extended hydraulic filter replacement interval
- Remote-mounted engine oil filter and fuel drain valve, for easy access
- Standard-equipped water separator
- Easier radiator cleaning
- Increased fuel tank capacity
- SCSH bushings on the work equipment extend the lubricating interval significantly

SpaceCab™

The new PC240-7's cabin space has been increased by 14%, offering an exceptionally-roomy operating environment.

- Sealed and pressurised cab with standard air conditioning
- Low-noise design
- Low-vibration design with cabin damper mounting
- OPG Level I (ISO) compliant cabin

In harmony with the environment

- The low emission engine meets EC Stage II emissions standards with increased power and machine productivity
- The economy mode reduces fuel consumption
- Low operating noise
- Designed for easy end-of-life recycling



EMMS

EMMS (Equipment Management and Monitoring System)

The EMMS is a highly sophisticated system, controlling and monitoring all the excavator functions. The user interface is highly intuitive and provides the operator with easy access to a huge range of functions and operating information.

Four working modes

The PC240-7 is equipped with three working modes: (A, E, B), plus a lifting mode (L). Each mode is designed to match the engine speed, pump speed, and system pressure with the current operating requirement. This provides the flexibility to match equipment performance to the job at hand.

The diagram illustrates the EMMS interface, which consists of a central display screen and a control panel below it. The screen displays various gauges and warnings, while the control panel features buttons for mode selection and system functions. Numbered callouts (1-15) identify specific elements on both the screen and the control panel.

On-screen symbols

- 1 Operating mode
- 2 Service hours meter
- 3 Travel speed
- 4 Engine water gauge
- 5 Engine water temperature warning
- 6 Hydraulic oil gauge
- 7 Hydraulic oil temperature warning
- 8 Fuel level gauge
- 9 Fuel low level warning
- 10 Swing lock
- 11 Pre-heat
- 12 Continuous/intermittent window wiper
- 13 Auto deceleration
- 14 PowerMax

Push-button control switches

- 1 'Active' mode
- 2 'Economy' mode
- 3 'Lifting' mode
- 4 'Breaker' mode
- 5 Travel speed selector switch
- 6 Auto deceleration
- 7 Window washer
- 8 Window wiper
- 9 Select (For attachment oil flow adjustment)
- 10 Maintenance mode
- 11 Screen brightness adjustment
- 12 Input (return)
- 13 Input (up)
- 14 Input (down)
- 15 Input (confirm)

Active mode

For maximum power and fast cycle times. Normally used for heavy operations such as hard digging and loading. This mode allows access to the 'PowerMax' function to temporarily increase the digging force by 7% for added power in tough situations.

Economy mode

The environmentally-friendly mode. For running more quietly during operations at night and/or in urban areas. Fuel consumption and exhaust emissions are reduced.

Breaker mode

Delivers optimal hydraulic pressure, flow and engine RPMs for powerful breaker operations.

Lifting mode

Increases the lifting capacity 7% by raising the hydraulic pressure. This mode supports safe lifting operations.

| Working mode | Application | Advantage |
|--------------|--------------|----------------------------------------------------------------------------------------------------------|
| A | Active mode | <ul style="list-style-type: none"> • Maximum production/power • Fast cycle times |
| E | Economy mode | <ul style="list-style-type: none"> • Excellent fuel economy |
| B | Breaker mode | <ul style="list-style-type: none"> • Optimum engine RPMs and hydraulic flow |
| L | Lifting mode | <ul style="list-style-type: none"> • Hydraulic pressure has been increased by 7% |



Hydraulic flow general adjustment screen in B (breaker) mode



Fine tune hydraulic flow adjustment screen in B (breaker) mode



Fine tune hydraulic flow adjustment screen in A (active) or E (economy) mode



Password screen

Easy to see and easy to use

Superb recognition colour LCD screens for each mode. Letters and numbers are combined with colour images for exceptionally clear and easy-to-read information. The high-resolution screen is easy to read in bright sunlight and in all lighting conditions.

Automatic three-speed travel

The travel speed is automatically shifted from high to low speed, according to the ground conditions.

| | High | Mid | Low |
|--------------|----------|----------|----------|
| Travel speed | 5,5 km/h | 4,2 km/h | 3,1 km/h |

Fingertip hydraulic pump oil flow adjustment

From the LCD monitor, you can automatically select the optimal hydraulic pump oil flow for breaking, crushing, and other operations in the B, A or E modes. Also, when simultaneously operating with attachments and work equipment, the flow to the attachment is reduced automatically, thus delivering a smooth movement of the work equipment.

Password protection

Prevents unauthorised machine use or transport. The engine cannot be started without your four-digit use or password.

For total security, the battery is connected directly to the starter motor. Both the starter and the engine need the password.

The password can be activated and deactivated upon request.

WORKING ENVIRONMENT

PC240-7's cab interior is spacious and provides a comfortable working environment...

SpaceCab™

Comfortable cab

The new PC240-7 inner cab volume is 14% greater than the Dash 6, offering an exceptionally comfortable operating environment. The large cab enables the seat, with headrest, to be reclined to horizontal.

Pressurised cab

The standard-equipped air conditioner, air filter and a higher internal air pressure resist dust entry into the cab.

Low-noise design

Noise levels are substantially reduced; engine noise as well as swing and hydraulics operations noise.

Cab damper mounting for low vibration levels

PC240-7 uses a new and improved viscous damping cab mount system that incorporates a longer stroke plus an added spring. The new cab damper mounting, combined with strengthened left and right-side decks, aids the reduction of vibrations to the operator's seat. Vibrations at the floor level have been reduced from 120 dB (VL) to 115 dB (VL).

dB (VL) is an index of vibration level. As it increases, vibration increases and operator comfort is reduced.

Riding comfort comparison

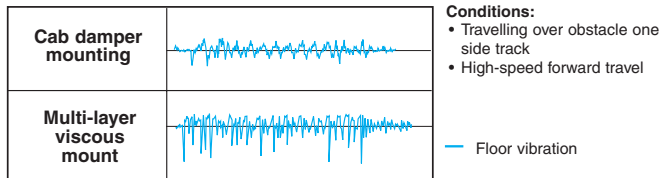

Vertical pitch oscillation on the graph shows the intensity of vibration



Outer air filter

Easy removal/installation of the air conditioner filter element, without tools facilitates easier cleaning.

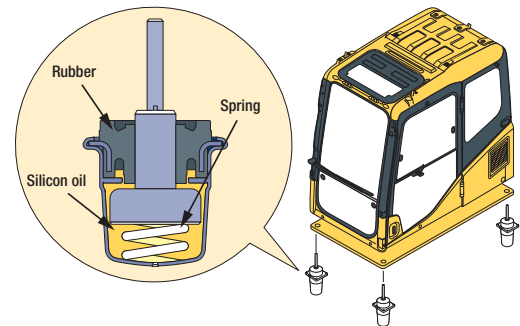

Roof hatch



12-Volt power supply and (optional) radio cassette



Climate control



Bottle holder and magazine rack

Safety features

Multi-position controls

The multi-position, proportional pressure control levers allow the operator to work in comfort whilst maintaining precise control. A double-slide mechanism allows the seat and controllers to move together, or independently, allowing the operator to position the controllers for maximum productivity and comfort.



Hot and cool box



3 button lever



Seat sliding range: 340 mm – increased by 120 mm over the Dash 6



Defroster/demister

Improved, wide visibility

The right side window pillar has been removed and the rear pillar reshaped to provide greater visibility. Blind spots have been decreased by 34%.

Pump/engine room partition

This prevents hydraulic oil from spraying onto the engine to reduce the risk of fire.

Thermal and fan guards

Are placed around high-temperature parts of the engine. The fan belt and pulleys are well protected.

Steps with non-skid surface and large handrail

Steps with non-slip surfacing ensure safer maintenance.

Thermal guard

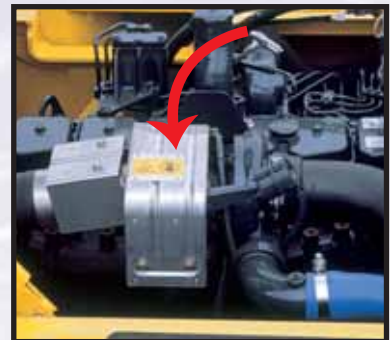

Non-slip sheet



Large handrail for safe access



PRODUCTIVITY FEATURES

High production levels and low fuel consumption

The increased output and fuel savings of the Komatsu SAA6D102E-2 engine result in increased productivity (tonnes per litre of fuel).

Engine

The PC240-7 gets its exceptional power and work capacity from a Komatsu SAA6D102E-2 engine. Its output is 125 kW/168 HP, providing increased hydraulic power and improved fuel efficiency.



Hydraulics

The unique two-pump system ensures smooth, simultaneous movement of the work equipment. Komatsu's exclusive HydraMind system controls both of the pumps for most-efficient use of engine power. The system also reduces hydraulic loss during operations. Optional, additional hydraulic circuits may be ordered.

Larger drawbar pull

PC240-7's maximum drawbar pull has been increased by 14% over Dash 6, providing superb slope climbing capability. Maximum drawbar pull: 20.570 kg

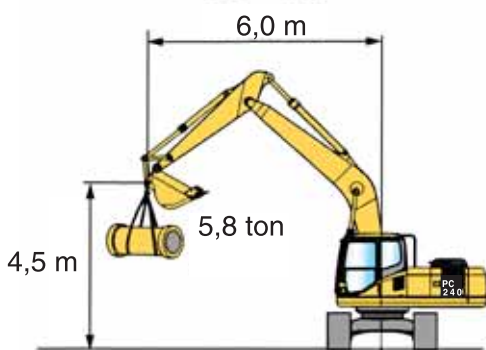

Extended digging height

PC240-7's maximum digging height is 10 m, facilitating jobs such as demolition and slope finishing that require longer reaches.

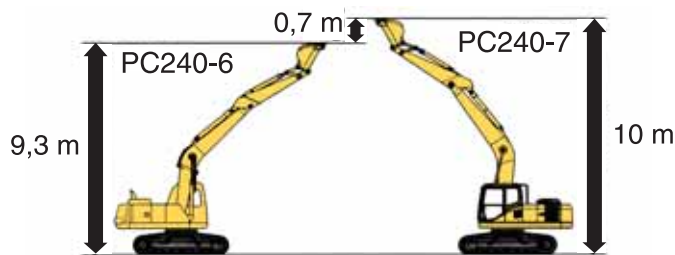

Larger arm crowd force and digging force provide increased production

Large bore cylinders are installed on the short arm to greatly increase digging forces and productivity in tough conditions. The arm crowd force has increased 8% and the bucket digging force has increased 7% when the PowerMax function is applied (compared to the PC240-6).

Bucket digging force*: 20.100 kg

Arm crowd force*: 16.400 kg

* Measured with PowerMax function, 2,0 m arm and ISO rating

The cross sections of boom and arm have been enlarged to provide superb durability.

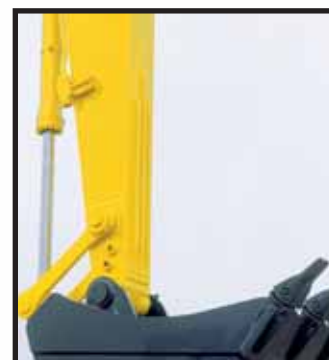

Heavy-duty arm

Greater lifting capacity

PC240LC-7's stability is greater than before. Also the hydraulic pressure has increased. The result: the PC240LC-7's lifting capacity is greater. Example: the over-side lifting capacity (reach 6,0 m, height 4,5 m) has increased from 5,0 tonnes to 5,8 tonnes compared to the PC240LC-6.

Excellent reliability and durability

Reliable components

All of the major machine components, such as the engine, hydraulic pump, hydraulic motor and control valves, are designed and manufactured by Komatsu. This guarantees that each component is expressly built for the class and model of machine. This ensures that the engineering, manufacturing standards and testing that go into each component are 'totally-Komatsu'.

Highly-rigid, robust work equipment

The strengthened boom and arm have large cross-sectional dimensions as well as continuous two-sided groove welding, improving the digging and side-contact strengths.

Sturdy frame structure

The revolving frame, centre frame and undercarriage have been designed using the most advanced three-dimensional Computer Aided Design (CAD) and Finite Elements Modelling (FEM) analysis technology.

Highly-reliable electronic devices

Exclusively-designed electronic devices are certified by severe testing.

- Controller
- Sensors
- Connectors
- Heat-resistant wiring

Metal guard rings

These protect all hydraulic cylinders and improve reliability.

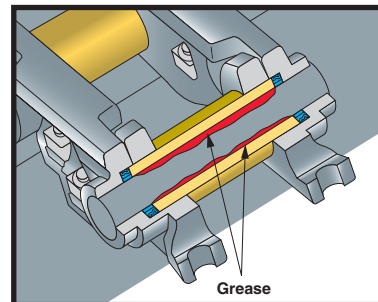

Grease-sealed track provides excellent undercarriage durability



Track link with strut
The PC240-7 uses track links with struts, providing superb durability

Harmony with the environment

Low-emission engine

Komatsu SAA6D102E-2 is EC Stage II compliant, with reduced NOx emissions, compared to the PC240-6.

Economy (environment) mode

'Economy' mode meets the needs of the 21st century. This mode offers the user fuel savings, quiet operation, and less CO₂ emissions.

Low noise

Noise has been reduced from the engine as well as from swing and hydraulic operations. The dynamic noise level is just 73 dB(A) at operator ear level (ISO 6369).

Easy end-of-life recycling

The PC240-7 is designed with the consideration of end-of-life recycling, effectively reducing its environmental impact.

- All exterior parts are made of steel.
- Extended engine oil, hydraulic oil and filter replacement intervals reduce environmental impact.
- All plastic parts are given a material code symbol.

VHMS

VHMS (Vehicle Health Monitoring System)

The VHMS's precise health-check system indicates all of the machine's running conditions. At the beginning of, and during, each work shift, abnormality information and machine functions can be checked from the operator's seat.

New features: VHMS machine health monitoring

- Up to four different mechanical system measurements can be monitored at the same time.
- A "Maintenance Indicator" function has been added. (Filter and oil replacement time display function).
- Mechanical system failures are now monitored, in addition to electrical system failures.
- Failures are indicated with a 6-digit failure code.

Displays running conditions and abnormality indications

At the operator's fingertips: the VHMS controller monitors engine oil level, cooling water level, fuel level, engine water temperature, engine oil pressure, battery charging level, air filter clogging, and more.

The monitor also indicates whenever abnormalities are detected.

Maintenance alert assistance

The VHMS monitor alerts when oil and filters need to be replaced.

Operation data memory

The system memorises machine operating data such as engine output, hydraulic pressure, and more.

Trouble data memory

The monitor stores and recalls electrical system and mechanical system failures and abnormalities for effective troubleshooting. The twenty most-recent electrical system failures are stored. Mechanical system failures cannot be erased, ensuring accurate documentation of vital service management information.

VHMS 'real time monitoring system'

The 'real time monitoring system' displays up to four different operating parameters simultaneously, giving the mechanic a total overview for faster troubleshooting. Parameters include operating conditions such as hydraulic oil pressure, engine RPMs, various voltages and currents, and even temperature measurement.

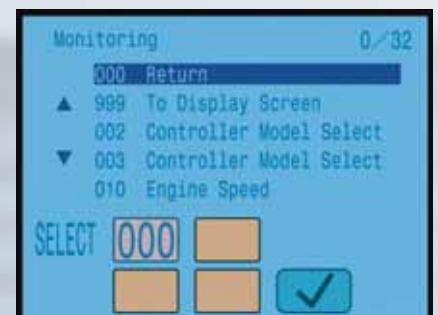

Real time monitoring

Reducing maintenance costs

Extended replacement intervals for engine oil and filters

New, high-performance filters are used in the hydraulic circuit and engine. Replacement intervals for the hydraulic oil filter have been significantly extended, reducing maintenance costs.

| Replacement intervals | PC240-7 |
|-----------------------|---------|
| Engine oil | 500 h |
| Engine oil filter | 500 h |
| Hydraulic oil | 5.000 h |
| Hydraulic oil filter | 1.000 h |

With SCSH bushings, all work equipment lubrication intervals have been extended

Newly-developed SCSH (Steel Copper Sinter Hard Material) bushings are used on all work equipment joints*. As a result, all work equipment bushing lubrication intervals have been significantly extended, with some joints only needing lubrication every 500 hours, thus reducing maintenance costs.

* Available for bucket pin, depending on bucket design

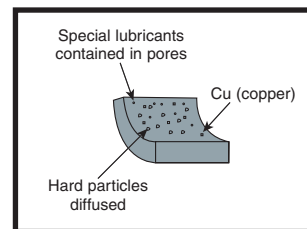

SCSH bushing

Tungsten carbide-injected bushing

Tungsten carbide is injected into the end faces of the arm-top bushing to form a hard film. This reduces the wear of the surface contact areas and fluttering of the bucket.

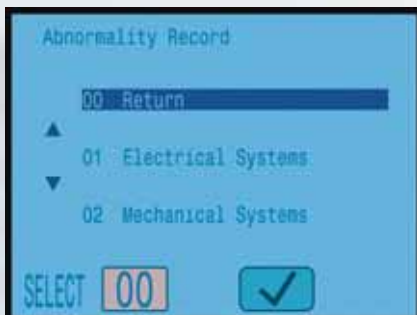

Trouble data memory



Maintenance record



Maintenance mode change

MAINTENANCE FEATURES

Easy maintenance

Komatsu designed the PC240-7 to have easy service access. By doing this, routine maintenance and servicing are less likely to be skipped. This can mean a reduction in costly downtime later on. Here are some of the many service features found on the PC240-7:

Easy radiator cleaning

The clearance between the radiator and oil cooler has been increased to facilitate radiator core cleaning with an air nozzle.



Water separator

This is standard equipment which removes any water that has become mixed with the fuel, preventing fuel system damage.



Easy access to the engine oil filter and fuel drain valve

The engine oil filter and fuel drain valve are mounted remotely to improve accessibility.



Auto greasing (optional)

A factory-installed Automatic Greasing System (AGS) ensures proper lubrication and saves driver maintenance downtime. Factory installation includes welding protective, heavy-duty line shielding onto the dipper arm during the manufacturing process, before painting. The central lubrication system uses reinforced hoses to carry the lubricant to all of the lubrication points, and is governed by several distribution blocks. Lubrication cycles may be adjusted to the operator's preference.



SPECIFICATIONS



ENGINE

Model..... Komatsu SAA6D102E-2
 Type..... Direct injection, water-cooled, emissionised, turbocharged, after-cooled diesel
 Rated capacity..... 125 kW/168 HP (ISO 9249 Net) at engine speed2.000 rpm
 No. of cylinders 6
 Bore/stroke 102/120 mm
 Displacement..... 5,88 ltr
 Battery 2 x 12 V/95 Ah
 Alternator..... 24 V/60 A
 Starter motor 24 V/5,5 kW
 Air filter type..... Double element type with monitor panel dust indicator and auto dust evacuator
 Cooling Suction type cooling fan with radiator fly screen



HYDRAULIC SYSTEM

Type..... HydrauMind. Closed-centre system with load sensing and pressure compensation valves
 Additional circuits..... Depending on the specification up to 2 additional circuits can be installed
 Main pump..... 2 variable displacement piston pumps supplying boom, arm, bucket, swing and travel circuits
 Maximum pump flow..... 2 x 220 ltr/min
 Relief valve settings
 Implement 380 kg/cm²
 Travel..... 380 kg/cm²
 Swing 290 kg/cm²
 Pilot circuit..... 33 kg/cm²



ENVIRONMENT

Engine emissions Fully complies with EC Stage II exhaust emission regulations
 Noise levels
 LwA external 104 dB(A) (2000/14/EC)
 LpA operator ear 73 dB(A) (ISO 6369 dynamic test)



OPERATING WEIGHT (APPR.)

Operating weight, including 5.850 mm one-piece boom, 3,0 m arm, 1,1 m³ bucket, operator, lubricant, coolant, full fuel tank and the standard equipment.



SWING SYSTEM

Type..... Axial piston motor driving through planetary double reduction gearbox
 Swing lock Electrically actuated wet multi-disc brake integrated into swing motor
 Swing speed 0 - 11,7 rpm



DRIVES AND BRAKES

Steering control 2 levers with pedals giving full independent control of each track
 Drive method Hydrostatic
 Travel operation Automatic 3-speed selection
 Gradeability 70%, 35°
 Max. travel speeds
 Lo / Mi / Hi..... 3,1 / 4,2 / 5,5 km/h
 Maximum drawbar pull 20.570 kg
 Brake system..... Hydraulically operated discs in each travel motor



UNDERCARRIAGE

Construction X-frame centre section with box section track-frames
 Track assembly
 Type..... Fully sealed
 Shoes (each side) 51 (PC240LC), 49 (PC240NLC)
 Tension..... Combined spring and hydraulic unit
 Rollers
 Track rollers (each side) 10 (PC240LC), 9 (PC240NLC)
 Carrier rollers (each side) 2



COOLANT AND LUBRICANT CAPACITY (REFILLING)

Fuel tank..... 400,0 ltr
 Radiator..... 30,9 ltr
 Engine oil..... 24,0 ltr
 Swing drive 6,6 ltr
 Hydraulic tank..... 143,0 ltr
 Final drive (each side) 4,5 ltr

| | MONO BOOM | | | | TWO-PIECE BOOM | | | |
|----------------------|------------------|-------------------------|------------------|-------------------------|------------------|-------------------------|------------------|-------------------------|
| | PC240LC-7 | | PC240NLC-7 | | PC240LC-7 | | PC240NLC-7 | |
| Triple grouser shoes | Operating weight | Ground pressure | Operating weight | Ground pressure | Operating weight | Ground pressure | Operating weight | Ground pressure |
| 600 mm | 24.200 kg | 0,51 kg/cm ² | 23.500 kg | 0,53 kg/cm ² | 25.525 kg | 0,55 kg/cm ² | 25.065 kg | 0,57 kg/cm ² |
| 700 mm | 24.500 kg | 0,44 kg/cm ² | 23.800 kg | 0,46 kg/cm ² | 25.815 kg | 0,48 kg/cm ² | 25.355 kg | 0,50 kg/cm ² |
| 800 mm | 24.800 kg | 0,39 kg/cm ² | 24.100 kg | 0,41 kg/cm ² | 26.105 kg | 0,42 kg/cm ² | 25.645 kg | 0,44kg/cm ² |
| 900 mm | 25.100 kg | 0,35 kg/cm ² | - | - | 26.395 kg | 0,38 kg/cm ² | - | - |

MACHINE DIMENSIONS

| MACHINE DIMENSIONS | | PC240LC-7 | PC240NLC-7 |
|--------------------|--------------------------------------|-----------------------|------------------|
| A | Overall width of upper structure | 2.710 mm | 2.710 mm |
| B | Overall height of cab | 3.015 mm | 3.015 mm |
| C | Overall length of basic machine | 5.225 mm | 5.030 mm |
| D | Tail length | 2.905 mm | 2.905 mm |
| | Tail swing radius | 2.940 mm | 2.940 mm |
| E | Clearance under counterweight | 1.100 mm | 1.100 mm |
| F | Machine tail height | 2.390 mm | 2.390 mm |
| G | Ground clearance | 440 mm | 440 mm |
| H | Track length on ground | 3.845 mm | 3.655 mm |
| I | Track length | 4.640 mm | 4.450 mm |
| J | Track gauge | 2.580 mm | 2.380 mm |
| K | Track shoe width | 600, 700, 800, 900 mm | 600, 700, 800 mm |
| L | Overall track width with 600 mm shoe | 3.180 mm | 2.980 mm |
| | Overall track width with 700 mm shoe | 3.280 mm | 3.080 mm |
| | Overall track width with 800 mm shoe | 3.380 mm | 3.180 mm |
| | Overall track width with 900 mm shoe | 3.480 mm | — |

MONO BOOM

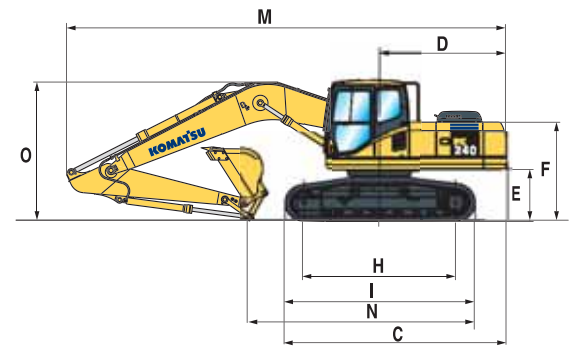
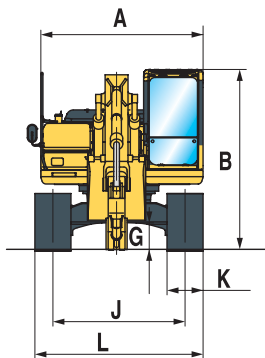

TWO-PIECE BOOM

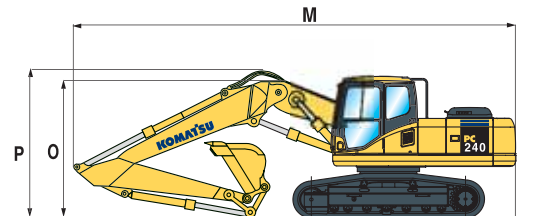

| ARM LENGTH | | MONO BOOM | | | | TWO-PIECE BOOM | | | |
|------------|---------------------------------|-----------|----------|----------|----------|----------------|-----------|-----------|----------|
| | | 2,0 m | 2,5 m | 3,0 m | 3,5 m | 2,5 m | 3,0 m | 3,5 m | |
| M | Transport length | 9.865 mm | 9.960 mm | 9.885 mm | 9.910 mm | 10.090 mm | 10.040 mm | 10.000 mm | |
| N | Length on ground (transport) | PC240LC | 6.600 mm | 6.115 mm | 5.390 mm | 4.950 mm | 6.795 mm | 6.170 mm | 8.895 mm |
| | | PC240NLC | 6.460 mm | 6.020 mm | 5.260 mm | 4.860 mm | 6.700 mm | 6.075 mm | 5.800 mm |
| O | Overall height (to top of boom) | 3.220 mm | 3.295 mm | 3.160 mm | 3.270 mm | 3.445 mm | 3.540 mm | 3.680 mm | |
| P | To top of hose | — | — | — | — | 3.015 mm | 3.015 mm | 3.155 mm | |



BUCKET OPTIONS & DIGGING FORCES

Specifications and equipment may vary according to regional availability

PC240LC-7 / PC240NLC-7

| BUCKET AND ARM COMBINATION | | | PC240LC | | | | PC240NLC | | | |
|----------------------------|---------------------|----------|---------|-------|-------|-------|----------|-------|-------|-------|
| Width | Capacity SAE | Weight | 2,0 m | 2,5 m | 3,0 m | 3,5 m | 2,0 m | 2,5 m | 3,0 m | 3,5 m |
| 600 mm | 0,48 m ³ | 620 kg | ○ | ○ | ○ | ○ | ○ | ○ | ○ | ○ |
| 800 mm | 0,70 m ³ | 690 kg | ○ | ○ | ○ | ○ | ○ | ○ | ○ | ○ |
| 1.000 mm | 0,93 m ³ | 780 kg | ○ | ○ | ○ | ○ | ○ | ○ | ○ | ○ |
| 1.200 mm | 1,17 m ³ | 890 kg | ○ | ○ | ○ | ○ | ○ | ○ | ○ | ○ |
| 1.400 mm | 1,41 m ³ | 980 kg | ○ | ○ | ○ | ○ | ○ | ○ | ○ | ○ |
| 1.500 mm | 1,53 m ³ | 1.040 kg | ○ | ○ | ○ | ○ | ○ | ○ | ○ | □ |
| 1.600 mm | 1,65 m ³ | 1.090 kg | ○ | ○ | ○ | □ | ○ | ○ | □ | △ |
| 1.800 mm | 1,89 m ³ | 1.200 kg | ○ | □ | △ | - | □ | △ | - | - |

Please consult with your distributor for the correct selection of buckets and attachments to suit the application. The recommendations are given as a guide only, based on typical operating conditions.

- Material weight up to 1,8 t/m³
- Material weight up to 1,5 t/m³
- △ Material weight up to 1,2 t/m³
- Not usable

A full range of Komatsu wear parts is available.

A wide range of attachments is available. Please consult your distributor for details of the full range.



| BUCKET AND ARM FORCE | | | | |
|------------------------------------|-----------|-----------|-----------|-----------|
| Arm length | 2,0 m | 2,5 m | 3,0 m | 3,5 m |
| Bucket digging force | 18.800 kg | 18.800 kg | 16.200 kg | 16.200 kg |
| Bucket digging force at power max. | 20.100 kg | 20.100 kg | 17.500 kg | 17.500 kg |
| Arm crowd force | 15.300 kg | 14.100 kg | 12.300 kg | 10.500 kg |
| Arm crowd force at power max. | 16.400 kg | 15.100 kg | 13.200 kg | 11.200 kg |

WORKING RANGES

PC240LC/NLC-7

MONO BOOM

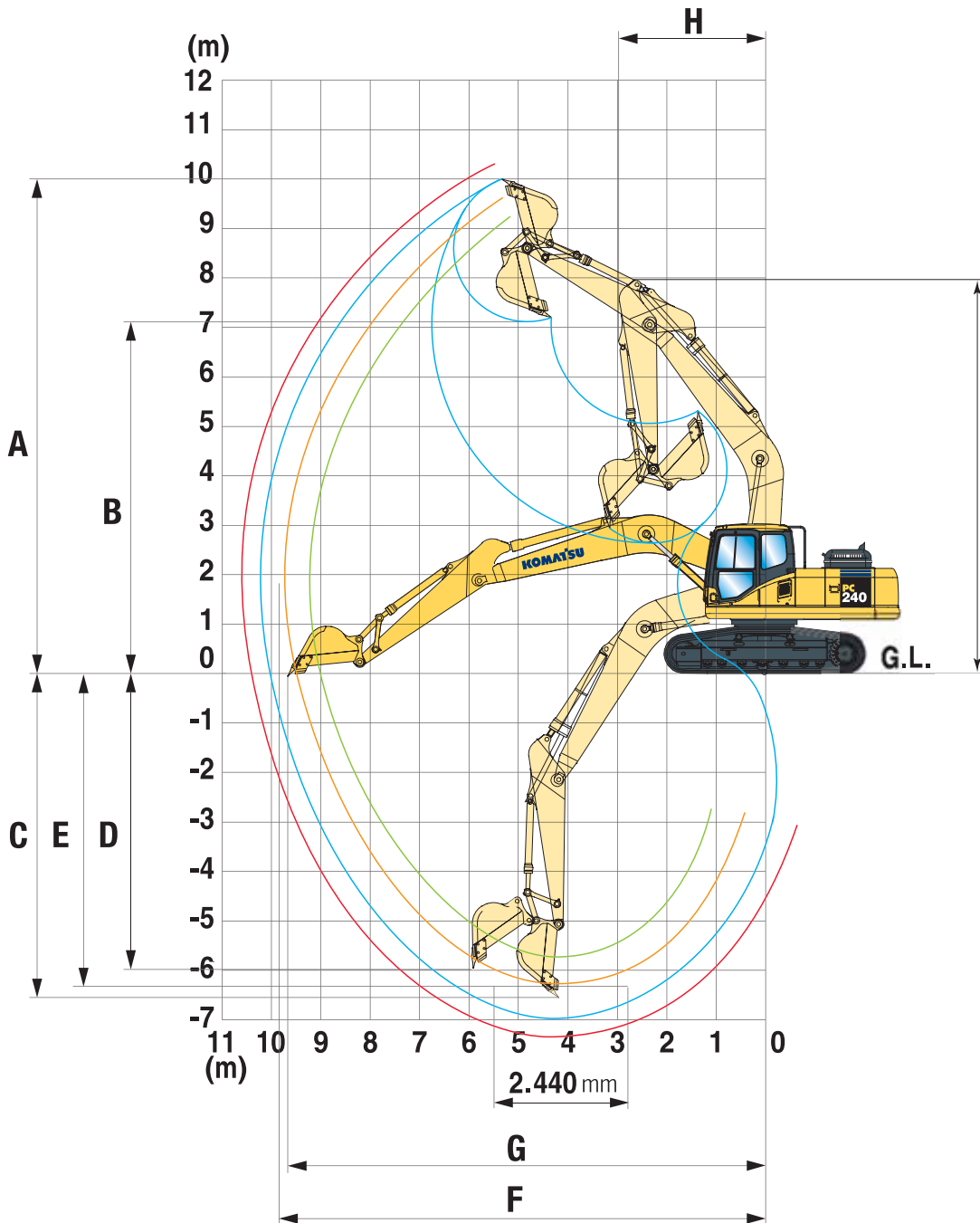

| ARM LENGTH | | 2,0 m | 2,5 m | 3,0 m | 3,5 m |
|------------|--------------------------------------------|----------|----------|-----------|-----------|
| A | Max. digging height | 9.665 mm | 9.790 mm | 10.000 mm | 10.300 mm |
| B | Max. dumping height | 6.715 mm | 6.860 mm | 7.035 mm | 7.360 mm |
| C | Max. digging depth | 5.825 mm | 6.320 mm | 6.920 mm | 7.320 mm |
| D | Max. vertical wall digging depth | 4.750 mm | 5.130 mm | 6.010 mm | 6.230 mm |
| E | Max. digging depth of cut for 2,44 m level | 5.585 mm | 6.100 mm | 6.700 mm | 7.150 mm |
| F | Max. digging reach | 9.270 mm | 9.480 mm | 10.180 mm | 10.580 mm |
| G | Max. digging reach at ground level | 9.070 mm | 9.670 mm | 10.020 mm | 10.420 mm |
| H | Min. swing radius | 3.300 mm | 3.320 mm | 3.450 mm | 3.340 mm |
| I | Max. height at min. swing radius | 8.060 mm | 8.160 mm | 8.110 mm | 8.140 mm |

TWO-PIECE BOOM

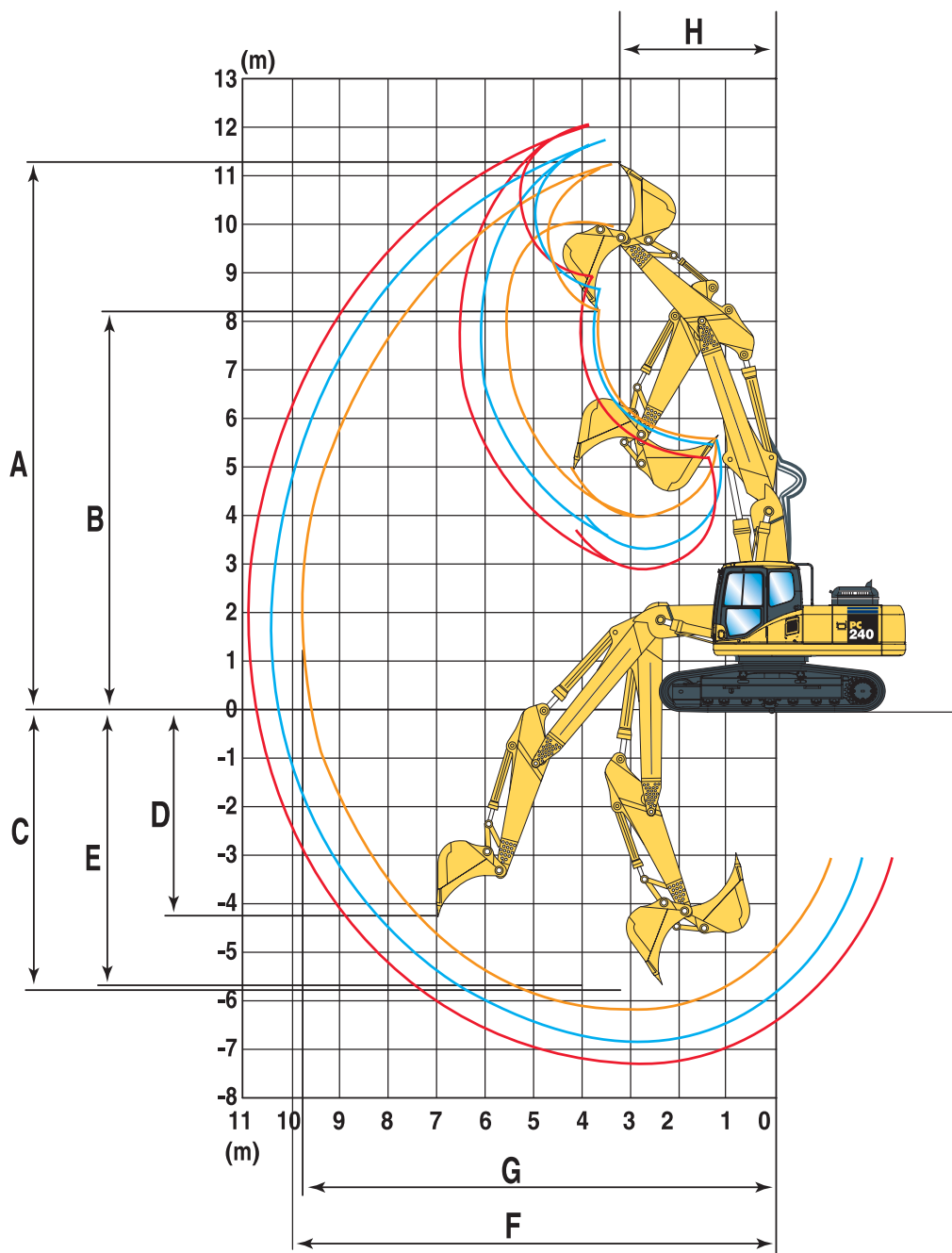



| ARM LENGTH | | 2,5 m | 3,0 m | 3,5 m |
|------------|--------------------------------------------|-----------|-----------|-----------|
| A | Max. digging height | 11.300 mm | 11.800 mm | 12.100 mm |
| B | Max. dumping height | 8.207 mm | 8.702 mm | 8.997 mm |
| C | Max. digging depth | 6.062 mm | 6.601 mm | 7.092 mm |
| D | Max. vertical wall digging depth | 4.653 mm | 5.545 mm | 6.003 mm |
| E | Max. digging depth of cut for 2,44 m level | 5.962 mm | 6.508 mm | 7.004 mm |
| F | Max. digging reach | 10.000 mm | 10.550 mm | 10.970 mm |
| G | Max. digging reach at ground level | 9.800 mm | 10.370 mm | 10.800 mm |
| H | Min. swing radius | 2.946 mm | 2.874 mm | 2.984 mm |



LIFTING CAPACITY

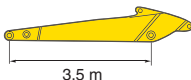

| Arm length | A | ⊗ | | 7,5 m | | 6,0 m | | 4,5 m | | 3,0 m | | 1,5 m | |
|------------|---|---|---|-------|---|-------|---|-------|---|-------|---|-------|---|
| | | ⌋ | ⌋ | ⌋ | ⌋ | ⌋ | ⌋ | ⌋ | ⌋ | ⌋ | ⌋ | ⌋ | ⌋ |

PC240LC-7 MONO BOOM

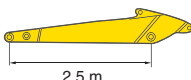
| | | | | | | | | | | | | | | |
|--------------------------------------------------------------------------------------------------------------------------------------------------------------------------------------------------------------------------------------|--------|----|--------|--------|--------|--------|--------|--------|---------|--------|---------|---------|---------|---------|
| With 700 mm shoe  3,5 m  730 kg 0,96 m ³ | 6,0 m | kg | *2.350 | *2.350 | *4.050 | *4.050 | | | | | | | | |
| | 4,5 m | kg | *2.400 | *2.400 | *5.050 | *4.200 | *5.200 | *5.200 | | | | | | |
| | 3,0 m | kg | *2.550 | *2.550 | *5.800 | 4.050 | *6.550 | 5.950 | *8.050 | *8.050 | *11.850 | *11.850 | | |
| | 1,5 m | kg | *2.850 | 2.650 | 6.050 | 3.850 | *8.000 | 5.550 | *10.850 | 8.750 | *10.850 | *10.850 | | |
| | 0,0 m | kg | *3.300 | 2.650 | 5.850 | 3.700 | 8.400 | 5.250 | *12.900 | 8.150 | *9.500 | *9.500 | *4.300 | *4.300 |
| | -1,5 m | kg | *4.050 | 2.850 | 5.750 | 3.600 | 8.150 | 5.000 | 13.500 | 7.900 | *11.850 | *11.850 | *7.350 | *7.350 |
| | -3,0 m | kg | 5.350 | 3.350 | 5.700 | 3.550 | 8.150 | 5.000 | 13.450 | 7.850 | *15.650 | *15.650 | *10.600 | *10.600 |
| | -4,5 m | kg | 7.050 | 4.400 | | | 8.250 | 5.100 | *13.100 | 8.000 | *19.350 | 16.500 | *14.400 | *14.400 |

| | | | | | | | | | | | | | | |
|--------------------------------------------------------------------------------------------------------------------------------------------------------------------------------------------------------------------------------------|--------|----|--------|--------|--------|-------|--------|--------|---------|--------|---------|---------|---------|---------|
| With 700 mm shoe  3,0 m  730 kg 0,96 m ³ | 6,0 m | kg | *3.000 | *3.000 | *4.450 | 4.250 | *4.900 | *4.900 | | | | | | |
| | 4,5 m | kg | *3.050 | *3.050 | *5.550 | 4.200 | *5.800 | *5.800 | | | | | | |
| | 3,0 m | kg | *3.200 | 2.950 | *6.250 | 4.050 | *7.150 | 5.900 | *9.050 | *9.050 | *14.450 | *14.450 | | |
| | 1,5 m | kg | *3.550 | 2.850 | 6.050 | 3.850 | *8.550 | 5.550 | *11.700 | 8.650 | *6.900 | *6.900 | | |
| | 0,0 m | kg | *4.050 | 2.900 | 5.900 | 3.700 | 8.450 | 5.250 | *13.500 | 8.150 | *8.100 | *8.100 | | |
| | -1,5 m | kg | *4.950 | 3.100 | 5.800 | 3.650 | 8.300 | 5.150 | 13.550 | 8.000 | *11.650 | *11.650 | *7.350 | *7.350 |
| | -3,0 m | kg | 5.850 | 3.700 | | | 8.250 | 5.100 | *13.600 | 8.000 | *16.750 | 16.350 | *11.350 | *11.350 |
| | -4,5 m | kg | 7.950 | 5.000 | | | 8.450 | 5.300 | *12.650 | 8.200 | *18.350 | 16.850 | | |

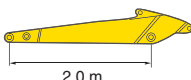
| | | | | | | | | | | | | | | |
|-----------------------------------------------------------------------------------------------------------------------------------------------------------------------------------------------------------------------------------------|--------|----|--------|-------|--------|-------|--------|--------|---------|--------|---------|---------|---------|---------|
| With 700 mm shoe  2,5 m  730 kg 0,96 m ³ | 6,0 m | kg | *4.750 | 4.400 | | | *5.650 | *5.650 | | | | | | |
| | 4,5 m | kg | *4.850 | 3.650 | *6.100 | 4.150 | *6.500 | 6.100 | *7.500 | *7.500 | | | | |
| | 3,0 m | kg | 5.150 | 3.300 | 6.200 | 4.000 | *7.750 | *5.800 | *10.150 | 9.100 | | | | |
| | 1,5 m | kg | 5.000 | 3.200 | 6.000 | 3.850 | 8.650 | 5.450 | *12.550 | 8.450 | | | | |
| | 0,0 m | kg | 5.150 | 3.250 | 5.900 | 3.750 | 8.400 | 5.250 | 13.700 | 8.100 | | | | |
| | -1,5 m | kg | 5.650 | 3.550 | 5.850 | 3.700 | 8.300 | 5.150 | 13.600 | 8.000 | *13.000 | *13.000 | *8.550 | *8.550 |
| | -3,0 m | kg | 6.850 | 4.350 | | | 8.350 | 5.200 | *13.700 | 8.100 | *19.850 | 16.550 | *13.900 | *13.900 |
| | -4,5 m | kg | *9.550 | 6.400 | | | | | *11.700 | 8.400 | *16.750 | *16.750 | | |

| | | | | | | | | | | | | | | |
|------------------------------------------------------------------------------------------------------------------------------------------------------------------------------------------------------------------------------------------|--------|----|--------|--------|--------|--------|--------|--------|---------|--------|---------|---------|---------|--------|
| With 700 mm shoe  2,0 m  730 kg 0,96 m ³ | 6,0 m | kg | *4.850 | 4.800 | | | *6.300 | 6.200 | | | | | | |
| | 4,5 m | kg | *4.950 | 3.950 | *5.600 | *4.050 | *7.100 | *6.000 | *8.400 | *8.400 | *12.000 | *12.000 | | |
| | 3,0 m | kg | *5.250 | *3.550 | 6.100 | 3.950 | *8.250 | 5.700 | *11.050 | 8.850 | | | | |
| | 1,5 m | kg | 5.350 | 3.400 | 5.900 | 3.800 | 8.550 | 5.400 | *13.200 | 8.250 | | | | |
| | 0,0 m | kg | 5.550 | 3.500 | 5.900 | 3.700 | 8.350 | 5.200 | *13.600 | 8.000 | | | | |
| | -1,5 m | kg | 6.200 | 3.900 | | | 8.300 | 5.150 | 13.600 | 8.000 | *13.550 | *13.550 | | |
| | -3,0 m | kg | 7.800 | 4.900 | | | 8.450 | 5.250 | *13.200 | 8.150 | *18.650 | 16.750 | *16.400 | *6.400 |
| | -4,5 m | kg | *9.750 | 7.850 | | | | | *10.450 | 8.550 | | | | |

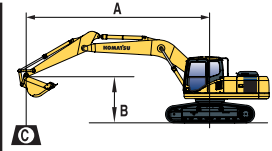





- A – Reach from swing center
- B – Bucket hook height
- C – Lifting capacities, including bucket linkage (200 kg) and bucket cylinder (140 kg)
- ⌋ – Rating over front
- ⌋ – Rating over side
- ⊗ – Rating at maximum reach

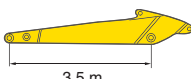

When removing bucket, linkage or cylinder, lifting capacities can be increased by their respective weights

With 700 mm shoe

PC240LC-7 TWO-PIECE BOOM

| | | | | | | | | | | | | | | |
|------------------------------------------------------------------------------------------------------------------------------------------------------------------------------------------------------------------------------------------|--------|----|--------|--------|--------|-------|--------|--------|---------|--------|---------|---------|---------|--------|
| With 700 mm shoe  3,5 m  730 kg 0,96 m ³ | 6,0 m | kg | *2.350 | *2.350 | *4.900 | 4.200 | *5.300 | *5.300 | | | | | | |
| | 4,5 m | kg | *2.350 | *2.350 | *5.850 | 4.100 | *6.400 | 6.100 | *6.350 | *6.350 | | | | |
| | 3,0 m | kg | *2.400 | 2.400 | 6.100 | 3.900 | *8.400 | 5.700 | *10.700 | 9.100 | *16.350 | *16.350 | | |
| | 1,5 m | kg | *2.600 | 2.300 | 5.850 | 3.700 | 8.450 | 5.300 | 13.200 | 8.250 | | | | |
| | 0,0 m | kg | *2.850 | 2.350 | 5.650 | 3.550 | 8.100 | 4.950 | 13.250 | 7.700 | *6.650 | *6.650 | | |
| | -1,5 m | kg | *3.300 | 2.550 | 5.550 | 3.450 | 7.950 | 4.800 | 13.000 | 7.500 | *9.350 | *9.350 | | |
| | -3,0 m | kg | *4.100 | 2.950 | 5.600 | 3.450 | 7.900 | 4.800 | 13.000 | 7.500 | *13.350 | *13.350 | *16.400 | *6.400 |
| | -4,5 m | kg | | | | | | | | | | | | |

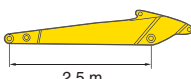
| | | | | | | | | | | | | | | |
|------------------------------------------------------------------------------------------------------------------------------------------------------------------------------------------------------------------------------------------|--------|----|--------|--------|--------|-------|--------|--------|---------|--------|--------|--------|---------|--------|
| With 700 mm shoe  3,0 m  730 kg 0,96 m ³ | 6,0 m | kg | *3.050 | *3.050 | *5.650 | 4.150 | *6.150 | *6.150 | *5.650 | *5.650 | | | | |
| | 4,5 m | kg | *3.000 | 2.800 | 6.250 | 4.050 | *7.450 | 6.000 | *7.650 | *7.650 | *7.500 | *7.500 | | |
| | 3,0 m | kg | *3.050 | 2.550 | 6.050 | 3.900 | 8.850 | 5.650 | *11.650 | 8.900 | | | | |
| | 1,5 m | kg | *3.200 | 2.500 | 5.850 | 3.700 | 8.400 | 5.250 | 13.750 | 8.150 | | | | |
| | 0,0 m | kg | *3.500 | 2.550 | 5.700 | 3.550 | 8.050 | 4.950 | 13.250 | 7.700 | | | | |
| | -1,5 m | kg | *4.000 | 2.800 | 5.650 | 3.500 | 8.000 | 4.900 | 13.100 | 7.600 | *8.650 | *8.650 | | |
| | -3,0 m | kg | | | 5.700 | 3.550 | 7.950 | 4.850 | 13.200 | 7.700 | | | *16.400 | *6.400 |
| | -4,5 m | kg | | | | | | | | | | | | |

| | | | | | | | | | | | | | |
|------------------------------------------------------------------------------------------------------------------------------------------------------------------------------------------------------------------------------------------|--------|----|--------|-------|-------|-------|--------|--------|---------|--------|--|--|--|
| With 700 mm shoe  2,5 m  730 kg 0,96 m ³ | 6,0 m | kg | *4.850 | 3.700 | 6.250 | 4.050 | *7.500 | 6.150 | *7.650 | *7.650 | | | |
| | 4,5 m | kg | *4.800 | 3.150 | 6.200 | 4.000 | *8.350 | *5.900 | *10.150 | 9.500 | | | |
| | 3,0 m | kg | 4.550 | 2.900 | 6.000 | 3.850 | 8.700 | 5.550 | *12.600 | 8.650 | | | |
| | 1,5 m | kg | 4.450 | 2.800 | 5.850 | 3.700 | 8.350 | 5.200 | 13.500 | 7.950 | | | |
| | 0,0 m | kg | 4.600 | 2.900 | 5.700 | 3.600 | 8.000 | 4.900 | 13.150 | 7.650 | | | |
| | -1,5 m | kg | 5.050 | 3.150 | 5.700 | 3.550 | 8.050 | 4.950 | 13.100 | 7.600 | | | |
| | -3,0 m | kg | | | | | 8.100 | 5.000 | | | | | |
| | -4,5 m | kg | | | | | | | | | | | |

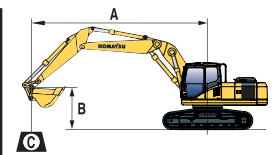

- A – Reach from swing center
- B – Bucket hook height
- C – Lifting capacities, including bucket linkage (200 kg) and bucket cylinder (140 kg)
- ⌋ – Rating over front
- ⌋ – Rating over side
- ⊗ – Rating at maximum reach

When removing bucket, linkage or cylinder, lifting capacities can be increased by their respective weights

With 700 mm shoe

* Load is limited by hydraulic capacity rather than tipping. Ratings are based on SAE Standard No. J1097. Rated loads do not exceed 87% of hydraulic lift capacity or 75% of tipping load.

| Arm length | A | 7,5 m | | 6,0 m | | 4,5 m | | 3,0 m | | 1,5 m | |
|------------|---|-------|--|-------|--|-------|--|-------|--|-------|--|
| | | | | | | | | | | | |
| | B | | | | | | | | | | |

PC240NLC-7 MONO BOOM

| | | | | | | | | | | | | | | |
|--------------------------------------------------------|--------|----|--------|--------|--------|-------|--------|--------|---------|--------|---------|---------|---------|---------|
| With 600 mm shoe 3,5 m 730 kg 0,96 m³ | 6,0 m | kg | *2.350 | *2.350 | *4.050 | 3.800 | | | | | | | | |
| | 4,5 m | kg | *2.400 | *2.400 | *5.050 | 3.700 | *5.200 | *5.200 | | | | | | |
| | 3,0 m | kg | *2.550 | *2.350 | 5.600 | 3.550 | *6.550 | 5.200 | *8.050 | *8.050 | *11.850 | *11.850 | | |
| | 1,5 m | kg | *2.850 | 2.250 | 5.400 | 3.350 | 7.850 | 4.850 | *10.850 | 7.600 | *10.850 | *10.850 | | |
| | 0,0 m | kg | *3.300 | 2.300 | 5.200 | 3.150 | 7.500 | 4.550 | 12.150 | 7.050 | *9.500 | *9.500 | *4.300 | *4.300 |
| | -1,5 m | kg | *4.050 | 2.450 | 5.100 | 3.050 | 7.200 | 4.300 | 11.850 | 6.800 | *11.850 | *11.850 | *7.350 | *7.350 |
| | -3,0 m | kg | 4.750 | 2.850 | 5.100 | 3.050 | 7.250 | 4.300 | 11.850 | 6.750 | *15.650 | *13.550 | *10.600 | *10.600 |
| | -4,5 m | kg | 6.250 | 3.800 | | | 7.350 | 4.400 | 12.000 | 6.900 | *19.350 | 13.900 | *14.400 | *14.400 |

| | | | | | | | | | | | | | | |
|--------------------------------------------------------|--------|----|--------|--------|--------|-------|--------|--------|---------|-------|---------|---------|---------|---------|
| With 600 mm shoe 3,0 m 730 kg 0,96 m³ | 6,0 m | kg | *3.000 | *3.000 | *4.450 | 3.750 | *4.900 | *4.900 | | | | | | |
| | 4,5 m | kg | *3.050 | 2.800 | *5.550 | 3.700 | *5.800 | 5.500 | | | | | | |
| | 3,0 m | kg | *3.200 | 2.550 | 5.600 | 3.550 | *7.150 | 5.150 | *9.050 | 8.200 | *14.450 | *14.450 | | |
| | 1,5 m | kg | *3.550 | 2.450 | 5.400 | 3.350 | 7.800 | 4.850 | *11.700 | 7.500 | *6.900 | *6.900 | | |
| | 0,0 m | kg | *4.050 | 2.450 | 5.250 | 3.200 | 7.500 | 4.550 | 12.150 | 7.050 | *8.100 | *8.100 | | |
| | -1,5 m | kg | *4.400 | 2.700 | 5.150 | 3.150 | 7.350 | 4.450 | 11.950 | 6.900 | *11.650 | *11.650 | *7.350 | *7.350 |
| | -3,0 m | kg | 5.200 | 3.200 | | | 7.350 | 4.450 | 11.950 | 6.900 | *16.750 | 13.800 | *11.350 | *11.350 |
| | -4,5 m | kg | 7.100 | 4.350 | | | 7.500 | 4.600 | 12.200 | 7.100 | *18.350 | 14.250 | | |

| | | | | | | | | | | | | | | |
|--------------------------------------------------------|--------|----|--------|-------|-------|-------|--------|-------|---------|--------|---------|---------|---------|---------|
| With 600 mm shoe 2,5 m 730 kg 0,96 m³ | 6,0 m | kg | *4.750 | 3.850 | | | *5.650 | 5.600 | | | | | | |
| | 4,5 m | kg | *4.850 | 3.200 | 6.700 | 3.800 | *6.500 | 5.400 | *7.500 | *7.500 | | | | |
| | 3,0 m | kg | 4.600 | 2.850 | 5.550 | 3.500 | *7.750 | 5.050 | *10.150 | 8.000 | | | | |
| | 1,5 m | kg | 4.450 | 2.750 | 5.350 | 3.350 | 7.700 | 4.750 | *12.450 | 7.300 | | | | |
| | 0,0 m | kg | 4.550 | 2.800 | 5.250 | 3.200 | 7.450 | 4.550 | 12.050 | 7.000 | | | | |
| | -1,5 m | kg | 5.050 | 3.100 | 5.200 | 3.200 | 7.350 | 4.450 | 11.950 | 6.900 | *13.000 | *13.000 | *8.550 | *8.550 |
| | -3,0 m | kg | 6.100 | 3.750 | | | 7.400 | 4.500 | 12.050 | 7.000 | *19.850 | 14.000 | *13.900 | *13.900 |
| | -4,5 m | kg | 9.150 | 5.550 | | | | | *11.700 | 7.250 | *16.750 | 14.500 | | |

| | | | | | | | | | | | | |
|--------------------------------------------------------|--------|----|--------|-------|-------|-------|--------|-------|---------|--------|---------|---------|
| With 600 mm shoe 2,0 m 730 kg 0,96 m³ | 6,0 m | kg | *4.850 | 4.250 | | | *6.300 | 5.450 | | | | |
| | 4,5 m | kg | *4.950 | 3.450 | 5.600 | 3.550 | *7.100 | 5.300 | *8.400 | *8.400 | *12.000 | *12.000 |
| | 3,0 m | kg | 4.950 | 3.100 | 5.450 | 3.450 | 7.950 | 5.000 | *11.050 | 7.750 | | |
| | 1,5 m | kg | 4.800 | 2.950 | 5.350 | 3.300 | 7.650 | 4.700 | 12.250 | 7.150 | | |
| | 0,0 m | kg | 4.950 | 3.050 | 5.250 | 3.200 | 7.450 | 4.500 | 11.950 | 6.900 | | |
| | -1,5 m | kg | 5.500 | 3.400 | | | 7.400 | 4.450 | 11.950 | 6.900 | *13.550 | *13.550 |
| | -3,0 m | kg | 6.950 | 4.250 | | | 7.500 | 4.550 | 12.150 | 7.050 | *18.650 | 14.150 |
| | -4,5 m | kg | *9.750 | 6.850 | | | | | *10.450 | 7.450 | | |

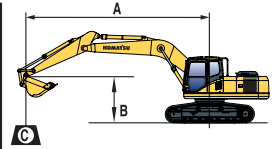

A – Reach from swing center

B – Bucket hook height

C – Lifting capacities, including bucket linkage (200 kg) and bucket cylinder (140 kg)



– Rating over front



– Rating over side



– Rating at maximum reach

When removing bucket, linkage or cylinder, lifting capacities can be increased by their respective weights

With 600 mm shoe

PC240NLC-7 TWO-PIECE BOOM

| | | | | | | | | | | | | |
|--------------------------------------------------------|--------|----|--------|--------|--------|-------|--------|--------|---------|--------|---------|---------|
| With 600 mm shoe 3,5 m 730 kg 0,96 m³ | 6,0 m | kg | *2.350 | *2.350 | *4.900 | 3.750 | *5.300 | *5.300 | | | | |
| | 4,5 m | kg | *2.350 | 2.250 | 5.800 | 3.600 | *6.400 | 5.400 | *6.350 | *6.350 | | |
| | 3,0 m | kg | *2.400 | 2.050 | 5.600 | 3.400 | 8.200 | 5.000 | *10.700 | 8.050 | *16.350 | *16.350 |
| | 1,5 m | kg | *2.600 | 2.000 | 5.350 | 3.200 | 7.750 | 4.650 | 12.600 | 7.200 | | |
| | 0,0 m | kg | *2.850 | 2.000 | 5.200 | 3.050 | 7.400 | 4.300 | 11.950 | 6.650 | *6.650 | *6.650 |
| | -1,5 m | kg | *3.300 | 2.150 | 5.100 | 2.950 | 7.250 | 4.150 | 11.700 | 6.450 | *9.350 | *9.350 |
| | -3,0 m | kg | *4.100 | 2.550 | 5.100 | 2.950 | 7.200 | 4.150 | 11.750 | 6.500 | *13.350 | 13.000 |
| | -4,5 m | kg | | | | | | | | | | |

| | | | | | | | | | | | | |
|--------------------------------------------------------|--------|----|--------|-------|--------|-------|--------|-------|---------|--------|--------|--------|
| With 600 mm shoe 3,0 m 730 kg 0,96 m³ | 6,0 m | kg | *3.050 | 2.800 | *5.650 | 3.650 | *6.150 | 5.550 | *5.650 | *5.650 | | |
| | 4,5 m | kg | *3.000 | 2.400 | 5.750 | 3.550 | *7.450 | 5.300 | *7.600 | *7.600 | *7.400 | *7.400 |
| | 3,0 m | kg | *3.050 | 2.200 | 5.550 | 3.400 | 8.100 | 4.950 | *11.600 | 7.850 | | |
| | 1,5 m | kg | *3.200 | 2.150 | 5.400 | 3.250 | 7.700 | 4.600 | 12.450 | 7.100 | | |
| | 0,0 m | kg | *3.500 | 2.200 | 5.250 | 3.100 | 7.350 | 4.300 | 11.950 | 6.650 | | |
| | -1,5 m | kg | *4.000 | 2.400 | 5.150 | 3.050 | 7.300 | 4.250 | 11.800 | 6.550 | *8.600 | *8.600 |
| | -3,0 m | kg | | | 5.200 | 3.100 | 7.250 | 4.200 | 11.900 | 6.650 | | |
| | -4,5 m | kg | | | | | | | | | | |

| | | | | | | | | | | | | |
|--------------------------------------------------------|--------|----|--------|-------|-------|-------|--------|-------|---------|--------|--|--|
| With 600 mm shoe 2,5 m 730 kg 0,96 m³ | 6,0 m | kg | *4.850 | 3.250 | 5.750 | 3.600 | *7.500 | 5.450 | *7.650 | *7.650 | | |
| | 4,5 m | kg | 4.550 | 2.750 | 5.700 | 3.500 | *8.350 | 5.200 | *10.100 | 8.400 | | |
| | 3,0 m | kg | 4.200 | 2.500 | 5.550 | 3.200 | 8.000 | 4.850 | *12.600 | 7.600 | | |
| | 1,5 m | kg | 4.100 | 2.450 | 5.350 | 3.200 | 7.650 | 4.550 | 12.200 | 6.900 | | |
| | 0,0 m | kg | 4.200 | 2.500 | 5.250 | 3.100 | 7.300 | 4.250 | 11.850 | 6.660 | | |
| | -1,5 m | kg | 4.600 | 2.750 | 5.200 | 3.100 | 7.350 | 4.300 | 11.800 | 6.600 | | |
| | -3,0 m | kg | | | | | 7.400 | 4.350 | | | | |
| | -4,5 m | kg | | | | | | | | | | |

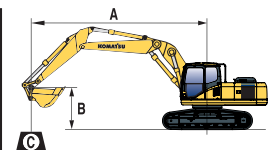

A – Reach from swing center

B – Bucket hook height

C – Lifting capacities, including bucket linkage (200 kg) and bucket cylinder (140 kg)



– Rating over front



– Rating over side



– Rating at maximum reach

When removing bucket, linkage or cylinder, lifting capacities can be increased by their respective weights

With 600 mm shoe

* Load is limited by hydraulic capacity rather than tipping. Ratings are based on SAE Standard No. J1097. Rated loads do not exceed 87% of hydraulic lift capacity or 75% of tipping load.

HYDRAULIC EXCAVATOR



STANDARD EQUIPMENT

- Komatsu SAA6D102E-2 125 kW direct injection emissionised Stage II intercooled turbocharged engine
- Double element type air cleaner with dust indicator and auto-dust evacuator
- Suction type cooling fan with radiator fly screen
- Automatic fuel line de-aeration
- Engine key stop
- Alternator 24 V/60 A
- Batteries 2 × 12 V/95 Ah
- Starter motor 24 V/5,5 kW
- Electronic closed-centre load sensing (E-CLSS) hydraulic system (HydraMind)
- Pump and engine mutual control (PEMC) system
- Multi-function colour monitor with equipment management monitoring system (EMMS)
- 4-working mode selection system; Active mode, economy mode, breaker mode and lifting mode
- Standard counterweight
- PowerMax function
- Auto-deceleration function
- Automatic engine warm-up system
- Engine overheat prevention system
- Fuel control dial
- Adjustable PPC wrist control levers with 3 button controls for arm, boom, bucket and swing
- PPC control levers and pedals for steering and travel
- One additional 2-way proportional service valve (full flow)
- Hydrostatic, 3-speed travel system with automatic shift and planetary gear type final drives, and hydraulic travel and parking brakes
- SpaceCab™; Highly pressurised and tightly sealed viscous mounted cab with tinted safety glass windows, opening roof hatch with window pull-up type front window with locking device, removable lower window, front window wiper with intermittent feature, ashtray, luggage box, floor mat
- Track roller guards
- Parts book and operator manual
- Lockable fuel cap and covers
- Remote greasing for swing circle and pins
- Fuel supply pump
- Track frame under-guards
- 12 Volt power supply
- Overload warning device
- Boom safety valves
- Climate control/Air conditioning
- Large handrails and rear-view mirrors
- Cigarette lighter
- Radio cassette preparation
- Beverage holder and magazine rack
- Electric horn
- Hot and cool box
- Toolkit and spare parts for first service
- Lights; 2 revolving frame lights and 1 boom light
- Suspension seat with adjustable arm rests and retractable seat belt
- Engine ignition can be password secured on request
- Standard colour scheme and decals

OPTIONAL EQUIPMENT

- LC and NLC undercarriages
- 600, 700, 800, 900 mm triple grouser track-shoes
- Mono boom / Two-piece boom
- 2,0 m, 2,5 m, 3,0 m, 3,5 m arms
- Automatic greasing system
- Additional hydraulic circuits
- OPG Level II top guard (FOPS)
- OPG Level II front guard (FOPS)
- Heated air suspension seat
- Full length track roller guards
- Radio cassette
- Service points
- Bio oil
- Additional cab roof lights + beacon preparation
- Rain visor
- Komatsu buckets
- Arm safety valve

KOMATSU®

Komatsu Europe International NV

Mechelsesteenweg 586
B-1800 VILVOORDE (BELGIUM)
Tel. +32-2-255 24 11
Fax +32-2-252 19 81
www.komatsueurope.com

UESS000904 02/2005

Materials and specifications are subject to change without notice.

KOMATSU® is a trademark of Komatsu Ltd. Japan.