

KOMATSU

PC20MR-2

OPERATING WEIGHT

2.140 - 2.610 kg

ENGINE POWER

15,7 kW / 21,1 HP @ 2.500 rpm

BUCKET CAPACITY

0,035 - 0,085 m³

PC
20MR-2



MINI-EXCAVATOR

PC20MR-2

WALK-AROUND

Tradition and Innovation

The new compact mini-excavator is the product of the competence and the technology that KOMATSU has been acquiring for over the past eighty years. The project has been developed with a constant attention to the needs of customers from all over the world; the result is a user-friendly machine, which offers top class performance.

Performance

The new short tail PC20MR-2 supplies optimal power and digging speed in confined spaces: yards, road works, demolition works, sewers, wherever traditional machines cannot work. Sturdiness and excellent stability ensure safety and confidence in any condition.

Komatsu CLSS

The **CLSS (Closed Load Sensing System)** hydraulic circuit guarantees power, speed and perfect control to all movements, including the combined ones. The main feature of this system is the connection between the variable displacement pump and the closed-centre circuit with load sensing, which allows operators to perform all movements with maximum efficiency, regardless of the load or the rpm. These characteristics are highlighted by the hydraulic servo-controls, which are by far the easiest to use and require minimum efforts to perform extremely precise manoeuvres.

Comfort

Despite its compact size, the PC20MR-2 offers a comfort which has no equals: spacious cab, **PPC** proportional servo-controls for all movements, sliding door, gas spring assisted front window, storage drawer, hook, cup holder, courtesy lamp and, upon request, radio.

Versatility

Many available configurations allow the operator to choose the right machine for the specific job: short or long arm, cab or canopy, rubber or steel shoes, extra counterweight. Moreover, the 1 / 2 way auxiliary hydraulic circuit consents to use multiple working tools, like the hammer, the clamshell bucket, the auger, etc.



OPERATING WEIGHT
2.140 - 2.610 kg

ENGINE POWER
15,7 kW / 21,1 HP @ 2.500 rpm

BUCKET CAPACITY
0,035 - 0,085 m³

Maintenance

All periodic inspection points are easily accessible through the bonnets. The fuel and the hydraulic oil tanks are located in a safe and easy to reach position. In addition, extra-ordinary maintenance can be performed by simply tilting the cab upwards: under the floor, the operator can find all major hydraulic components, like the main valve or the swing motor.



ORFS hydraulic face seal connectors and DT electric connectors improve the reliability of the machine and make repairs easier and faster.

Special technical solutions have allowed to extend up to 500 hours the intervals for most ordinary maintenance operations, such as pin greasing or engine oil replacement.

Also, to avoid possible leakage, all tanks are equipped with a draining hose: this confirms once again the attention KOMATSU pays to the environment.

OPERATOR'S ENVIRONMENT



The spacious cab has been developed with exceptional care for details, making the work environment noiseless and comfortable. Special attention has been paid to the internal layout: ergonomic and dedicated PPC controls; speed switch button on the panel instead of pedal, which consequent offers more floor room; adjustable seat; gas spring assisted front window opening; efficient heating and ventilation system. Last, but not least, the upper rail type sliding door makes getting on/off the machine very easy and safe in any situation.

STRONG POINTS

Engine

The KOMATSU engine supplies the required power, keeping the fuel consumption very low. By taking advantage of state of the art technologies, it ensures minimum levels of noise and emissions (STAGE 2).



Automatic Shift Down

Once turned on, this device automatically adjusts the hydraulic travel motor to the working conditions: maximum displacement for faster movements, minimum displacement for top drawbar pull. This process doesn't require operator's support.



Attachment line

The 1 / 2 way auxiliary hydraulic circuit allows the use of several tools for different purposes: hammer, clamshell bucket, and so on. The switching between the two options is realised simply by means of a cock, which is located on the side of the machine and right behind a little bonnet.



X-Frame

The new casted type X-frame ensures maximum stress resistance and optimal stress distribution; this shape makes the machine much more rigid and reliable. In addition, it facilitates the usual undercarriage cleaning operations and the spoil removing.



Additional Counterweight

The opportunity to quickly add and remove counterweight allows conversion to the PC20MR-2 from *0-Tail* to *Short Tail* and vice-versa, thereby satisfying specific job-site requirements. Such counterweight increases the machine stability and the lifting capacity.



DIMENSIONS & WORKING RANGE

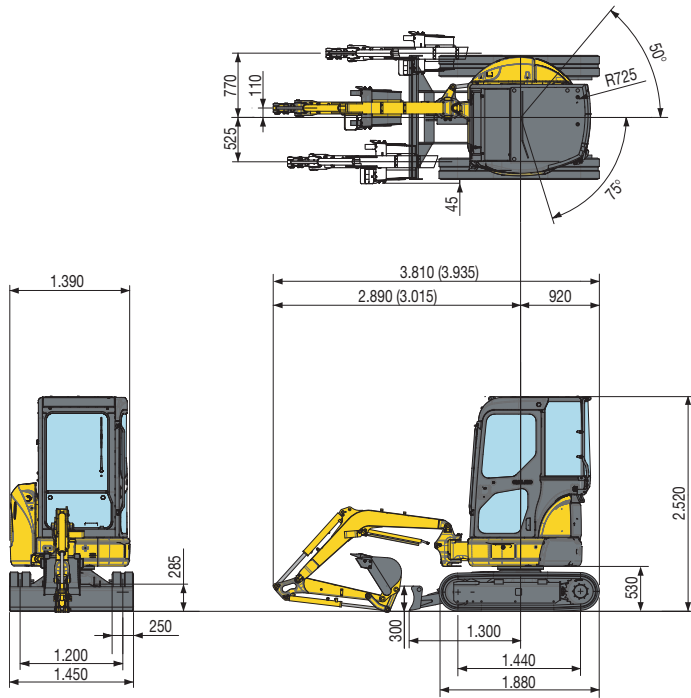

| BUCKET RANGE | | | |
|--------------|-----------------------------------|-----------|--------------|
| Width mm | Capacity m ³ (ISO7451) | Weight kg | No. of teeth |
| 250 | 0,035 | 30 | 2 |
| 350 | 0,055 | 40 | 3 |
| 450 | 0,07 | 50 | 4 |
| 550 | 0,085 | 60 | 5 |

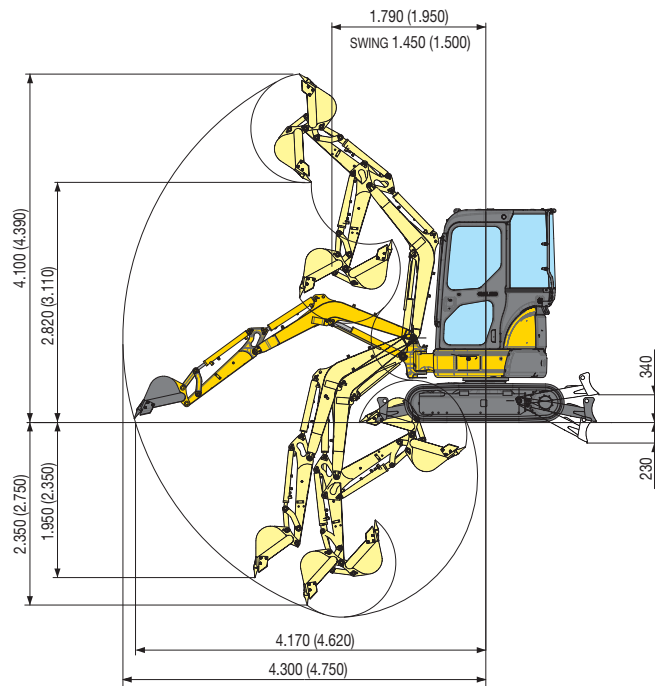

PC20MR-2 + Rubber Shoes + X-Weight + Blade Down

| Arm length 1.015 mm | | | | | | |
|---------------------|-----------|---------|---------|------|---------------|------|
| A \ B | 2 m | | 3 m | | Max. outreach | |
| | Front. | Side | Front. | Side | Front. | Side |
| 3 m | - | - | - | - | (*) 535 | 520 |
| 2 m | (*) 630 | (*) 630 | (*) 550 | 460 | (*) 555 | 365 |
| 1 m | (*) 1.380 | 805 | (*) 710 | 445 | (*) 595 | 335 |
| 0 m | (*) 1.550 | 785 | (*) 805 | 435 | (*) 645 | 355 |
| -1 m | (*) 1.240 | 795 | - | - | (*) 710 | 490 |

| Arm length 1.365 mm | | | | | | |
|---------------------|-----------|------|---------|---------|---------------|------|
| A \ B | 2 m | | 3 m | | Max. outreach | |
| | Front. | Side | Front. | Side | Front. | Side |
| 3 m | - | - | (*) 400 | (*) 400 | (*) 450 | 400 |
| 2 m | - | - | (*) 440 | (*) 440 | (*) 470 | 310 |
| 1 m | (*) 1.115 | 820 | (*) 625 | 445 | (*) 505 | 285 |
| 0 m | (*) 1.540 | 775 | (*) 780 | 425 | (*) 550 | 300 |
| -1 m | (*) 1.405 | 780 | (*) 725 | 425 | (*) 605 | 380 |

NOTE:

Ratings are based on ISO standard 10567. Rated loads do not exceed 87% of hydraulic lift capacity or 75% of tipping load.
 - The values marked with an asterisk (*) are limited by the hydraulic capacities - Calculations are based on the machine resting on a uniform and firm surface
 - The lifting point is a hypothetical hook placed behind the bucket.

SPECIFICATIONS



ENGINE

The new generation engine has been developed to comply with the strictest emission controls (STAGE 2).

ModelKomatsu 3D76E-5
 Type emissionised 4-cycle diesel engine
 Displacement..... 1.115 cm³
 Bore × stroke.....76 × 82 mm
 No. of cylinders 3
 Combustiondirect injection
 Aspiration natural
 Engine power
 at rated engine speed2.500 rpm
 ISO 14396..... 15,7 kW / 21,1 HP
 SAE J1349 15,5 kW / 20,8 HP
 Max. torque/engine speed 66,7 Nm @ 1.600 rpm
 Cooling system..... water
 Air filter type dry
 Starting..... electric motor with pre-heating air system
 for cold climate



SWING SYSTEM

The rotation is operated by means of an orbital hydraulic motor.
 Single ball-bearing ring with internal, induction hardened toothring.
 Centralised lubrication of the unit.
 Swing speed.....8,9 rpm



TRANSMISSION

Type2 speed hydrostatic transmission,
 controlled and steered by means of two levers and two pedals
 Hydraulic motors 2 × axial pistons
 Reduction system..... epicyclic reduction gears
 Max. drawbar pull.....2.020 daN (2.060 kgf)
 Travel speed2,8 - 4,6 km/h



OPERATING WEIGHT

Operating weight with standard bucket, fully serviced, +75 kg operator (ISO 6016).
 Operating weight with cab and rubber shoes 2.315 kg
 Operating weight with cab and steel shoes 2.420 kg
 Canopy -175 kg (optional)
 Additional counterweight +190 kg



BLADE

Typeelectro-welded, single unit structure
 Width × height 1.450 × 300 mm
 Max. lifting above ground level..... 340 mm
 Max. depth below ground level 230 mm



HYDRAULIC SYSTEM

Type Komatsu CLSS
 Main pumps.....variable displacement pump
 + gear pump
 Max. pump flow.....53,9 + 15,2 ltr/min
 Max. operating pressure:
 Working equipment.....24,5 MPa (245 bar)
 Hydraulic motors:
 Travel..... 2 × variable displacement
 Swing 1 × fixed displacement
 Hydraulic cylinders (bore × stroke):
 Boom70 × 435,5 mm
 Arm65 × 451 mm
 Bucket.....50 × 469,5 mm
 Boom swing70 × 429,5 mm
 Blade.....65 × 135 mm
 Bucket digging force (ISO 6015) 1.883 daN (1.920 kg)
 Arm crowd force (ISO 6015):
 1.015 mm arm..... 1.363 daN (1.390 kg)
 1.365 mm arm..... 1.133 daN (1.155 kg)
 The digging equipment is fully controlled by PPC servo-controls. All movements are stopped by lifting the safety levers on the tiltable case.



UNDERCARRIAGE

Central lower casted X-frame and carriage frame with boxed section.
 Shoes (each side) 39
 Track rollers (each side)..... 3
 Shoe width 250 mm
 Ground pressure (standard).....0,27 kg/cm²



ELECTRIC SYSTEM

Voltage..... 12 V
 Battery 45 Ah
 Alternator 40 A
 Starter motor 1,4 kW



ENVIRONMENT

Vibration levels (EN 12096:1997)*
 Hand/arm ≤ 2,5 m/s² (uncertainty K = 1,2 m/s²)
 Body ≤ 0,5 m/s² (uncertainty K = 0,2 m/s²)
 * for the purpose of risk assessment under directive 2002/44/EC, please refer to ISO/TR 25398:2006.



SERVICE CAPACITIES

Fuel tank 28 ltr
 Radiator and system 3,0 ltr
 Engine oil 3,4 ltr
 Hydraulic system 29 ltr

MINI-EXCAVATOR

STANDARD EQUIPMENT

- ROPS (ISO 3471) / FOPS (ISO 10262) tiltable cab with heating
- Sliding door
- Rubber shoes
- Two speeds with "Automatic Shift Down"
- 1.015 mm digging arm
- 1 / 2 way auxiliary hydraulic circuit up to the boom
- Blade
- Adjustable suspension seat
- Lifting cylinder guard
- Working light on boom

OPTIONAL EQUIPMENT

- ROPS (ISO 3471) / FOPS (ISO 10262) tiltable canopy
- Steel shoes
- 1.365 mm digging arm
- Bucket range (250 - 550 mm)
- 1.300 mm ditch cleaning bucket
- Extension of the auxiliary hydraulic circuit up to the arm, with quick couplings
- Boom, arm and blade safety valves
- Overloading alarm
- Travel acoustic alarm
- Rotating beacon
- Biodegradable oil
- Rearview mirrors
- Cab/canopy working lights
- Front and top protection guards



Manufacturer: Komatsu Utility Europe

Head Office · via Atheste 4 · 35042 Este (Padova) - Italy

Tel. +39 0429 616111 · Fax +39 0429 601000 · www.komatsueurope.com · utility@komatsu.it



Komatsu Europe International NV
 Mechelsesteenweg 586
 B-1800 VILVOORDE (BELGIUM)
 Tel. +32-2-255 24 11
 Fax +32-2-252 19 81
www.komatsueurope.com

WESS004202 12/2010

Materials and specifications are subject to change without notice.

KOMATSU is a trademark of Komatsu Ltd. Japan.