

CRAWLER EXCAVATOR SERIES PC130-6

KOMATSU



The machine shown may vary according to territory specifications

HYDRAUMIND

**The outstanding heart of
Komatsu's new excavator**

Designed and manufactured in Europe using the patented Komatsu HydrauMind Hydraulic System which offers world-class operation and performance.

HYDRAULIC EXCAVATOR PC130-6

FLYWHEEL HORSEPOWER: 64 KW (87 PS) at 2200 rpm

BUCKET CAPACITIES: 0.24 ~ 0.84 m³ SAE

WEIGHT RANGE: UP TO 13,300 kg

**THE KOMATSU DASH 6 EXCAVATOR FEATURES THE REMARKABLE
AND UNIQUE HYDRAUMIND**



What is HYDRAUMIND?

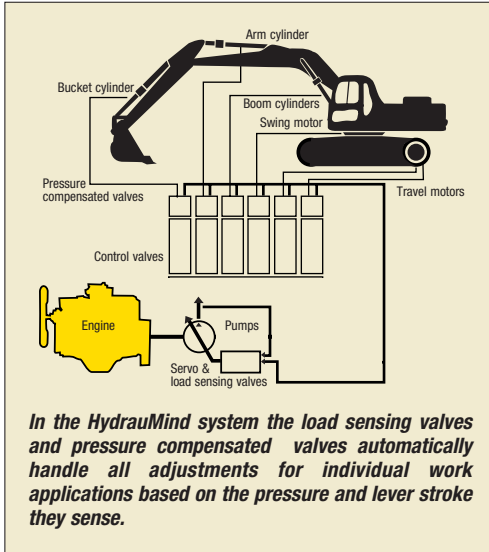

It's Komatsu's sophisticated excavator technology that succeeded in making truly advanced excavators available now.

The system is essentially hydraulic and electronically controlled. Its strength lies in its simplicity.

HYDRAUMIND incorporates many major innovations. Komatsu has almost 200 patents relating to the Dash 6.

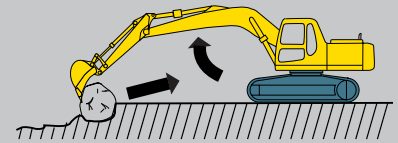

Working through soft rock or pulling up boulders is easy because the system precisely controls boom raise, preventing the cutting edge from slipping.

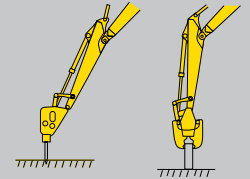

Switching attachments is easy - even with such things as breakers or crushers, which require a different amount of oil - because the oil flow can be adjusted simply by selecting the appropriate mode on the monitor panel.

Benefits of HYDRAUMIND

Power, versatility, manoeuvrability, controlability-you name it. Never has there been an excavator so easy to operate, so natural, so intuitive, so responsive.

For example, when digging and the ground condition changes... you don't have to think about changing lever strokes because HYDRAUMIND - instantly, silently and automatically sends just the right amount of oil to the actuators, at just the right pressure to accommodate the change.

When you move boom, arm and bucket at the same time... all the equipment works naturally with the optimum combination of speed, and power as if it was a human hand.

HYDRAUMIND also makes it easy to change or add valves and work equipment.

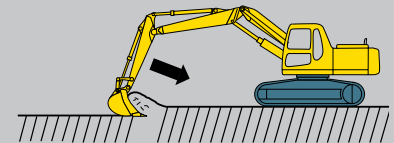

Fully-loading buckets is easy, because during simultaneous operations the work equipment can move slowly under maximum power.

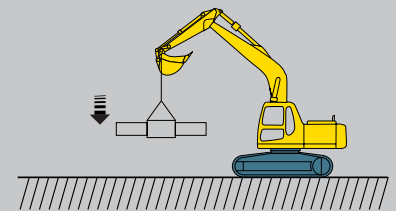

Fine-controlling is easy because the system keeps work equipment speed at a steady constant no matter what size the load.

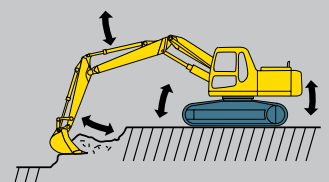

Chassis-shake is reduced during simultaneous operations because the work load causes no change in the work equipment speed.



Easy Operation

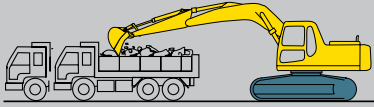

H.O. mode. Designed for Heavy-duty Operation.

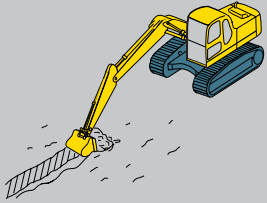

G.O. mode. Designed for General-digging Operation.

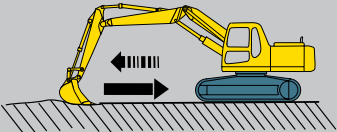

F.O. mode. Designed for Finishing Operation.

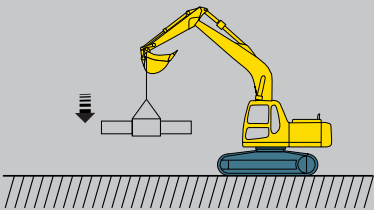

L.O. mode. Lifting is easy because the system keeps work equipment speed at a steady constant no matter what size the load.

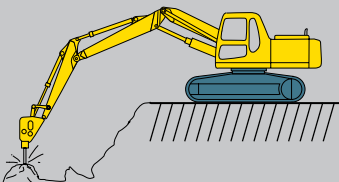

B.O. mode. Designed for Breaker Operation.

Clock

Also used to display diagnostic information during servicing.

Service meter

Water temperature

Fuel gauge

Warning lights

The operator is immediately warned of any major problems.

Auto deceleration

When selected, automatically reduces engine speed after a short period if the wrist control levers are in neutral.



Travel speed

3-speed fully automatic travel. Automatically changes from High to low when travelling up steep slopes and can be locked in to low for safe descents and manoeuvring.

POWER MAX

The Power Max function gives a temporary burst of maximum power to break through tough digging conditions.

ACTIVE MODE

The unique active mode function boosts work equipment speed in high load applications to greatly reduce cycle times.

ACTIVE POWER MAX

The exclusive Active Power Max function combines the increased digging force of Power Max with the speed of the Active Mode.

+

=





Visibility has been enhanced with additional window area by attaching the wiper to the cab frame.

Comfortable Operation

OUTSTANDING OPERATOR COMFORT

The cab offers unparalleled space for the driver. There is generous leg and head room, and space to stow personal goods in a compartment behind the seat.

The multi-adjustable seat can be set to create the ideal individual working position for any operator, and this adds up to superb operator comfort.

The smooth action, short lever stroke requires only gentle pressure. Excellent all-round visibility is provided by large, panoramic windows. Moreover an excellent view of the attachments can be obtained via a wide-opening roof hatch.

The cab also features a wiper that is mounted directly onto the cab frame, a Komatsu patented design feature. When the wiper is turned off, it is stowed to one side, with no contact with the actual windscreen. This means that if the operator needs to open the front windscreen he doesn't first have to disconnect the wiper.

Using the benefits obtained from HydrauMind the operator can with the minimum of effort perform precision work from a position of complete comfort. The position of the rotatable monitor display can be easily adjusted, and an inclined dashboard places switches and the fuel control dial within easy reach and view.

The tiltable, height-adjustable semi-bucket seat provides, superb operator comfort - even when the machine is working long hours in tough conditions. The operator can select virtually any seat position to suit himself so that all instruments and controls are within easy reach. The high quality finish of the cab interior - including effective noise insulation - reduces operator fatigue significantly.



Easy Serviceability

SELF-DIAGNOSTICS

The Monitor panel incorporates a sophisticated diagnostic system. If a serious fault develops the operator is warned immediately, whereas more minor problems are stored in the memory to be checked by service staff later. The memory can be extremely useful for service staff to diagnose intermittent problems. Diagnosis is further assisted by using the facility to display the operating condition of the machine, for example engine speed and pump pressures.

ACCESSIBLE SERVICE LOCATIONS

The operator and service staff can safely climb onto the machine using the large handrails, and all service items can be easily accessed using the wide opening doors and hoods. Routine maintenance has been simplified by relocating the radiator and window washer bottles to allow fluid checks from ground level.



Accessible service locations.





ENGINE

Model	Komatsu S4D102E
Type	4-cycle, water-cooled, direct-injection
Aspiration	Turbocharged
No. of cylinders	4
Bore	102 mm
Stroke	120 mm
Piston displacement	3.92 ltr.
Flywheel horsepower (SAE J1349)	64 kW (86 HP) at 2200 RPM
(DIN 6270 NET)	64 kW (87 PS) at 2200 RPM
Governor	All-speed, mechanical



HYDRAULIC SYSTEMS

Type	HydrauMind (Hydraulic Mechanical Intelligence New Design) system
	Closed-center system with load sensing valves and pressure compensated valves
Main pump:	
Type	Variable displacement piston pump
Pump for	Boom, arm, bucket, swing and travel circuits
Maximum flow	1 x 226 ltr./min.
Sub-pump for control circuit.....	Gear pump
Hydraulic motors:	
Travel	2 x Axial piston motor with parking brake
Swing.....	1 x Axial piston motor with swing holding brake
Relief valve setting:	
Implement circuits	325 kg/cm ²
Travel circuit	325 kg/cm ²
Swing circuit	275 kg/cm ²
Pilot circuit	30 kg/cm ²
Hydraulic cylinders:	
Number of cylinders - bore x stroke:	
Boom	2 - 105 mm x 990 mm
Arm	1 - 115 mm x 1175 mm
Bucket	1 - 95 mm x 885 mm



SWING SYSTEM

Driven by	Hydraulic motor
Swing reduction	Planetarydouble reduction
Swing circle lubrication	Grease-bathed
Swing lock	Oil disc brake
Swing speed	12.0 RPM



STEERING

Steering/travelling controls are activated with either hand levers or foot pedals. Pushing both levers (or pedals) moves machine forward. Pulling them back makes machine go into reverse. Setting one lever (or pedal) in neutral and the other in forward enables machine to make a pivot turn. Pushing one forward while pulling the other backward makes machine counterrotate on the spot.



DRIVES & BRAKES

Steering control	Two levers
Drive method	Fully hydrostatic type
Travel motor	Axial piston motor, in-shoe design
Reduction system	Eccentral differential, planetary reduction
Max. drawbar pull	10200 kg (100 kN)
Max. travel speed LO/Hi	2.7 / 5.5 km/h
Service brake	Hydraulic lock type
Parking brake	Oil disc brake



UNDERCARRIAGE

Center frame	X-frame
Seal of track	Sealed track
Track adjuster	Hydraulic type
No. of shoes	42 eah side
No. of carrier rollers	1 each side
No. of track rollers	7 each side



COOLANT & LUBRICANT CAPACITY

Fuel tank	230 ltr.
Radiator	18.2 ltr.
Engine	16.0 ltr.
Final drive, each side	2.5 ltr.
Swing drive	2.5 ltr.
Hydraulic tank	100 ltr.



OPERATING WEIGHT

Operating weight including 4600 mm one-piece boom, 2900 mm arm HCU, 0.68 m³ bucket, operator, lubricant, coolant and full fuel tank: 13,050 kg.



CAB

Sound-insulated all-weather steel cab, safety glass windows, pull-up front window, lockable door, window wiper, electric horn, cab lamp, adjustable suspension seat with reclining devices, monitor system and gauges.

Dynamic low noise level	LWA101
	LPA 77

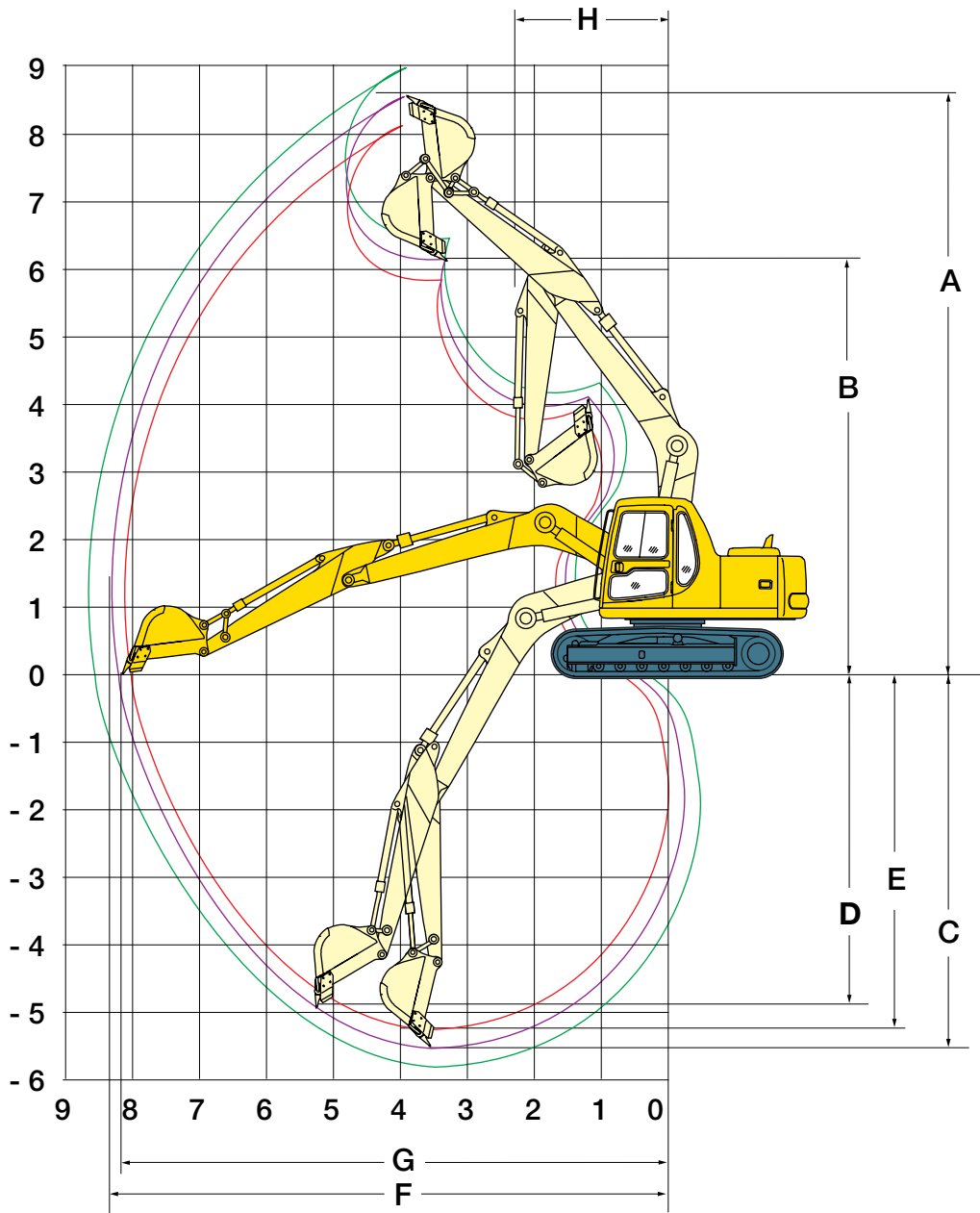

Arm length		2100 mm	2500 mm	2900 mm
A	Max. digging height	8345 mm	8610 mm	8970 mm
B	Max. dumping height	5905 mm	6170 mm	6535 mm
C	Max. digging depth	5115 mm	5520 mm	6015 mm
D	Max. vertical wall digging depth	4520 mm	4940 mm	5360 mm
E	Max. digging depth of cut for 2500 mm	4875 mm	5315 mm	5835 mm
F	Max. digging reach	7925 mm	8290 mm	8785 mm
G	Max. digging reach at ground level	7795 mm	8170 mm	8665 mm
H	Min. swing radius	2290 mm	2330 mm	2485 mm
	Bucket digging force*	8500 kg	8500 kg	8500 kg
	Arm crowd force*	7500 kg	6300 kg	5250 kg

* At power max.

LIFTING CAPACITIES

PC130-6

When removing bucket, linkage or cylinder, lifting capacities can be increased by their respective weights

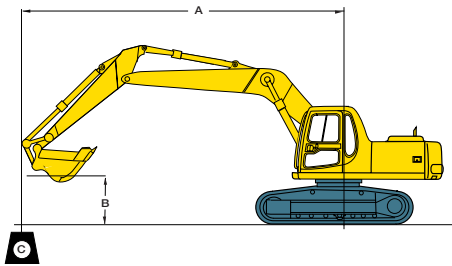

A – Reach from swing center

B – Bucket hook height

– Rating over front

– Rating over side

– Rating at maximum reach

Arm length	A	B			7.0 m		6.0 m		4.5 m		3.0 m		1.5 m	
With 700 mm shoe Bkt 422 kg 	6.0 m	kg	*1500	*1500			*2350	2250						
	4.5 m	kg	*1350	*1350	2100	1650	*2750	2250						
	3.0 m	kg	*1350	1350	2050	1650	2750	2200	*3450	*3450				
	1.5 m	kg	*1450	1250	2000	1550	2600	2050	4250	3300	*6850	6250		
	0.0 m	kg	*1600	1250	1900	1500	2500	1950	3950	3050	7950	5650		
	-1.5 m	kg	1750	1350	1900	1450	2400	1850	3800	2900	7700	5450	*3850	*3850
	-3.0 m	kg	2150	1650			2400	1850	3800	2900	7750	5500	*6400	*6400
-4.5 m	kg	*3150	2450					3900	3000	*6400	5650	*10250	*10250	
With 700 mm shoe Bkt 422 kg 	6.0 m	kg	*1800	*1800										
	4.5 m	kg	*1700	*1700			2800	2250	*3150	*3150				
	3.0 m	kg	*1700	1550	2050	1650	2750	2200	*3950	3550	*5150	*5150		
	1.5 m	kg	*1800	1450	2000	1800	2650	2100	4200	3300	*7850	6150		
	0.0 m	kg	1850	1450	1950	1550	2550	2000	3900	3000	*7550	5700		
	-1.5 m	kg	2050	1600			2500	1950	3900	3000	7900	5600	*4400	*4400
	-3.0 m	kg	2600	2050					3850	2950	7950	5700	*7600	*7600
-4.5 m	kg	*3300	*3300							*5400	*5400			
With 700 mm shoe Bkt 422 kg 	6.0 m	kg	*2250	*2250					*3350	*3350				
	4.5 m	kg	*2050	2000			2750	2200	*3500	*3500				
	3.0 m	kg	*2050	1700			2700	2150	*4300	3450	*5900	*5900		
	1.5 m	kg	2000	1550	2000	1600	2600	2050	4150	3250	8350	6000		
	0.0 m	kg	2000	1600			2500	2000	3950	3050	*6800	5650		
	-1.5 m	kg	2250	1800			2500	1950	3900	3000	7900	5600	*4750	*4750
	-3.0 m	kg	2950	2350					3900	3000	*7400	5750	*8800	*8800
-4.5 m	kg													

* Load is limited by hydraulic capacity rather than tipping.
Ratings are based on SAE Standard No. J1097.
Rated loads do not exceed 87% of hydraulic lift capacity or 75% of tipping load.

BUCKET AND ARM COMBINATION

PC130-6

Bucket capacity (heaped)		Width without side cutters	Width with side cutters	Weight without side cutters	No. of teeth	Arm		
SAE, PCSA	CECE					2100 mm	2500 mm	2900 mm
0.24 m ³	0.22 m ³	450 mm	575 mm	314 kg	3	○	○	○
0.28 m ³	0.26 m ³	550 mm	675 mm	339 kg	3	○	○	○
0.35 m ³	0.33 m ³	600 mm	725 mm	367 kg	3	○	○	○
0.47 m ³	0.43 m ³	750 mm	875 mm	419 kg	4	○	○	□
0.59 m ³	0.53 m ³	900 mm	1025 mm	469 kg	4	○	□	△
0.68 m ³	0.61 m ³	1000 mm	1125 mm	497 kg	4	□	△	-

These charts are based on over-side stability with fully loaded bucket at maximum reach.
Please consult your local dealer for the bucket range available in your region.

○ Material weight up to 1.8 t/m³
□ Material weight up to 1.5 t/m³
△ Material weight up to 1.2 t/m³
- Not for use

GENERAL DIMENSIONS PC130-6

A	Overall width of upper structure with mirror & handrail	2760 mm
B	Overall width of upper structure	2455 mm
C	Overall height of cab	2715 mm
D	Overall length of basic machine	3860 mm
E	Tail length / tail swing radius	2130 mm
F	Clearance under counterweight	855 mm
G	Machine tail height	1805 mm
H	Ground clearance	400 mm
I	Track length on ground	2750 mm
J	Track length	3480 mm
K	Track gauge	1960 mm
L	Track shoe width	500, 600, 700 mm
M	Overall track width with 500 mm shoe	2460 mm
	600 mm shoe	2560 mm
	700 mm shoe	2660 mm

TRANSPORT DIMENSIONS

Arm	2100 mm	2500 mm	2900 mm
N	7590 mm	7595 mm	7510 mm
O	4515 mm	4250 mm	4090 mm
P	2620 mm	2715 mm	3075 mm

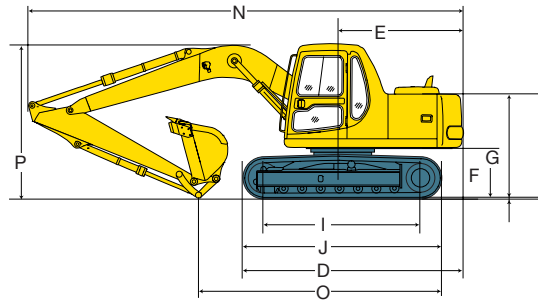
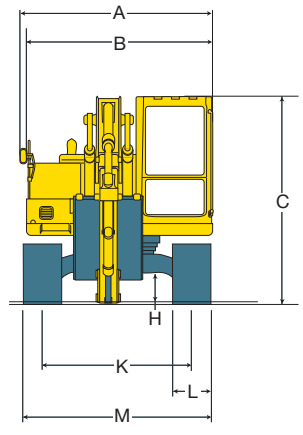

COMPONENTS DIMENSIONS AND WEIGHTS

PC130-6

Specifications and equipment may vary according to regional availability

(APPROXIMATE WEIGHTS)

BASIC MACHINE

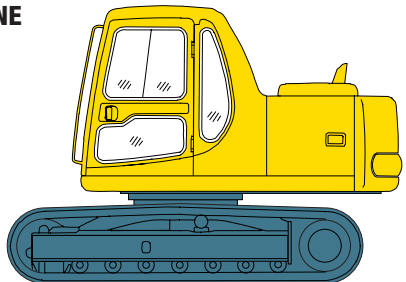

Shoe width	Weight
500 mm	10360 kg
600 mm	10550 kg
700 mm	10730 kg

BOOM WITH ARM CYLINDER

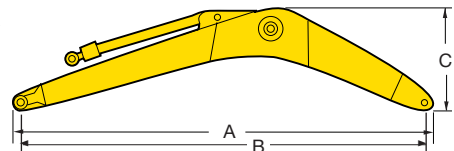

A	B	C	Weight
4738 mm	4600 mm	1310 mm	1060 kg

BOOM CYLINDER

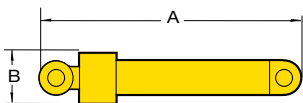

A	B	Weight
1400 mm	170 mm	80 kg

ARM WITH BUCKET CYLINDER AND LINKAGE

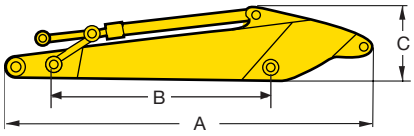

Arm	2.1 m	2.5 m	2.9 m
A	2860 mm	3270 mm	3770 mm
B	2100 mm	2500 mm	2900 mm
C	635 mm	575 mm	640 mm
Weight	440 kg	460 kg	610 kg

KOMATSU CRAWLER EXCAVATOR SERIES PC130-6



STANDARD EQUIPMENT

Standard and optional equipment may vary. Consult your Komatsu dealer for more information.

- Air cleaner, dry type with auto dust evacuator and dust indicator
- Alternator, 25 A
- Auto decelerator
- Automatic engine warm-up system
- Automatic de aeration for fuel line
- Batteries (2 x 12 volt, 80 Ah)
- Boom cylinder safety valve
- Cab: all-weather sound suppression type with safety glass windows, pull-up type front window with lock device, removable lower windshield, lockable door, floor mat, windshield wiper with intermittent feature, cigarette lighter and ashtray.
- Control levers (adjustable wrist control with PPC system)
- Cooling fan: suction
- Drive system: hydrostatic, high-low travel system with auto-shift
- Engine overheat prevention system
- Fuel control dial
- Heater
- Horn, electric
- HydrauMind and Electronic Closed-centre Load Sensing System (ECLSS)
- Hydraulic track adjusters
- Active mode
- Instrument panel: Electronic Monitor and Control Console (EMACC) system
- 1-Piece Boom
- Active power maximizing system
- Working mode selection system
- Radiator & oil cooler with dust net
- Rearview mirrors (RH & LH)
- Fully adjustable suspension seat
- Starting motor: 24 volt, 4.5 kW direct electric
- Vandalism protection locks

OPTIONAL EQUIPMENT

- Airconditioner
- Additional hydraulic circuit
- Arm cylinder safety valve
- Dozer blade
- Heated seat
- Fire extinguisher
- Fuel supply pump
- Radio-cassette
- Track roller guards
- Additional work lamps

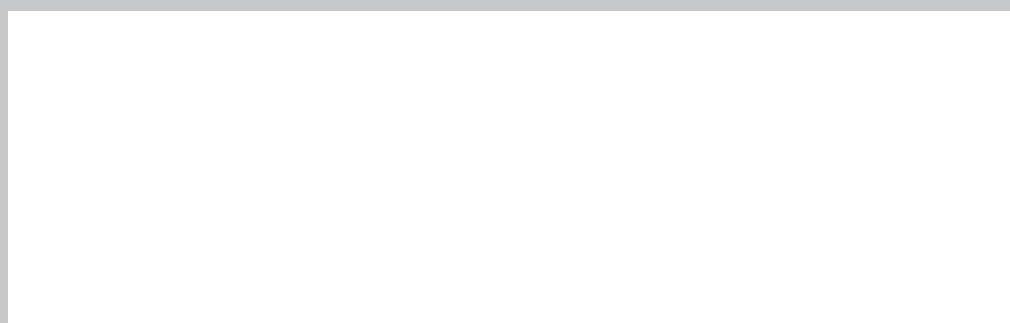

KOMATSU

**Komatsu Europe
International N.V.**

Mechelsesteenweg 586
B 1800 VILVOORDE (BELGIUM)

Tel. (32)2/255 24 11
Fax (32)2/252 19 81
Telex 24.380 Eukom b
Cable: KOMASEI, Bru B